

Making Your (Power)Point

An Introductory Guide to Digital Presentation Design for Lawyers

Jonah Perlin*

We live in a digital presentation generation.¹ Information once conveyed in writing through memos, letters, and emails or orally delivered in meetings and speeches presented without demonstratives is now increasingly (and sometimes exclusively) delivered using digital presentations created in software programs like PowerPoint, Keynote, and Google Slides.² These digital presentations are used by conference presenters, consultants, clergy, entrepreneurs, executives, engineers, marketing professionals, military commanders, sales associates, students,

.....

* Jonah Perlin, Associate Professor of Law, Legal Practice, Georgetown University Law Center. I am grateful for the diligent research assistance of Laixin Li, Annie Moody, Natalie Sherburne, Claire Jenets, and Muye Zhang. This piece was also strengthened by conversations with participants at the 2019 Applied Legal Storytelling Conference at the University of Colorado Law School, the 2019 Empire State Legal Writing Conference at New York Law School, and the 2018 Legal Writing Institute One-Day Conference at the University of Pittsburgh Law School. I also want to express my gratitude to Nicholas Boyle and Jaye Campbell for teaching me the importance of presentation design for lawyers and my Legal Practice colleagues at the Georgetown University Law Center who have provided written feedback, opportunities to workshop this idea, and encouragement to integrate these lessons into our own classrooms. Thanks also to Sean Kiley for detailed comments on the full draft. Finally, I want to thank my editors from *LC&R*, Kristen Murray and Amy Griffin, for their exceptional additions to the project

¹ See, e.g., NANCY DUARTE, *SLIDE:OLOGY: THE ART AND SCIENCE OF CREATING GREAT PRESENTATIONS* xviii (2008) (“Presentations have become the de facto business communication tool.”); Rachel G. Stabler, *Screen Time Limits: Reconsidering Presentation Software for the Law School Classroom*, 23 *LEGAL WRITING* 173, 173 (2019) (“PowerPoint is ubiquitous. If anything, it is now ubiquitous even to say that PowerPoint is ubiquitous.”).

² This article uses the phrase “digital presentation” to mean any file created using digital presentation software. The primary reason it adopts such a broad definition is that when a law student or lawyer is asked to “make a PowerPoint” or “put together a slide deck,” that request can mean many different things. It could mean build a slide presentation to be shown while giving a talk or leading a meeting. It could mean prepare a set of slides that are used during a presentation *and* shared as a summary following that presentation. It could mean create a lengthy printed document created in “slideware” but consumed by the audience as a written report. Or it could mean prepare a one-page infographic to be shared with a supervisor or client. But all of these requests come in a similar form: make me a “PowerPoint” or “slides.” As a result, for some of these deliverables the term “digital presentation” may feel like a misnomer given that they are never presented at all. They are instead documents created using presentation software for desktop publishing. That said, the principles and approaches outlined in this article apply equally to creating all of these different documents.

teachers, and many others.³ Sometimes these digital presentations supplement or accompany oral speeches. Other times they are stand-alone documents consumed independently by their audience on screen or in print. In fact, by some estimates there are over 500 million users of PowerPoint alone and more than thirty-five million PowerPoint presentations given every day.⁴

Lawyers are no exception to this fundamental shift in how we communicate.⁵ For example, trial lawyers rely on digital presentations to display key evidence to judges and juries—and judges and juries often expect lawyers to use visuals or presentations when making their case.⁶ Transactional lawyers use digital presentations at each stage in the business lifecycle: to present and propose complex deal structures, to make recommendations on strategies to mitigate tax liability, and to outline restructuring approaches to corporate boards in the event that a business fails. Regulatory lawyers use digital presentations to convey advice to trade organizations and lobby government officials. Non-profit lawyers use digital presentations to pitch ideas to potential donors and document success for the media. Clinical students use digital presentations to make recommendations to their underrepresented pro bono clients. Law professors use digital presentations to present their research to students and peers.⁷ And lawyers from all practice areas use digital presentations to solicit business as well as teach and consume Continuing Legal Education classes.

Yet despite this ubiquity, lawyers are rarely trained how to efficiently create effective digital presentations. Perhaps this should not come as a surprise. Although “[l]awyers operate in an increasingly and almost exclusively, digital world,”⁸ they “are often the last to wake up to trends.”⁹ But

³ See, e.g., STEPHEN M. KOSSLYN, *CLEAR AND TO THE POINT: 8 PSYCHOLOGICAL PRINCIPLES FOR COMPELLING POWERPOINT PRESENTATIONS 1* (2007) (“Whatever business we’re in . . . we are very likely to suffer through frequent PowerPoint presentations.”); Chris Kolmar, *50 Jobs That Use Powerpoint The Most*, ZIPPPIA (Jan. 1, 2017), <https://www.zippia.com/advice/what-jobs-use-powerpoint/>.

⁴ *10 Little-Known Facts about PowerPoint*, POLL EVERYWHERE BLOG, <https://blog.polleverywhere.com/powerpoint-infographic/> (last visited Mar. 21, 2021).

⁵ See, e.g., CLIFF ATKINSON, *BEYOND BULLET POINTS 1* (4th ed. 2018) (discussing the dueling uses of PowerPoint during an important 2005 products liability trial); G. CHRISTOPHER RITTER, *CREATING WINNING TRIAL STRATEGIES AND GRAPHICS 6–7* (2d ed. 2015); Adam L. Rosman, *Visualizing the Law: Using Charts, Diagrams, and Other Images to Improve Legal Briefs*, 63 J. LEGAL EDUC. 70, 70 (2013); Jeff Bennion, *How To Present Beautiful Evidence*, ABOVE THE LAW (Feb. 9, 2016), <https://abovethelaw.com/2016/02/how-to-present-beautiful-evidence/>.

⁶ See RITTER, *supra* note 5, at 6–7; Steve Johansen & Ruth Anne Robbins, *Art-iculating the Analysis: Systemizing the Decision to Use Visuals as Legal Reasoning*, 20 LEGAL WRITING 57, 61 (2015) (noting that judges are calling for lawyers to use visuals); Ellie Margolis, *Is the Medium the Message?*, 12 LEGAL COMM. & RHETORIC 1, 26 (2015) (“It has long been accepted that images are useful at the trial level, in presenting information to juries.”).

⁷ See, e.g., Deborah J. Merritt, *Legal Education in the Age of Cognitive Science and Advanced Classroom Technology*, 14 B.U. J. SCI. & TECH. L. 39, 40 (2008); Stabler, *supra* note 1, at 173–74; Paul Wangerin, *Technology in the Service of Tradition: Electronic Lectures and Live-Class Teaching*, 53 J. LEGAL EDUC. 213, 220 (2003).

⁸ Margolis, *supra* note 6, at 1.

at the same time it is important to remember that digital presentations are neither new nor novel. PowerPoint was introduced in 1987,¹⁰ Apple's competing product, Keynote, came out in 2003,¹¹ and Google Slides debuted in 2007.¹²

At this point, lawyers have been creating (and writing about) digital presentations for more than a quarter of a century.¹³ Yet too many lawyers still do not see digital presentations as a distinct genre of legal communication that can and must be learned. Instead, many lawyers seem to believe that creating effective digital presentations requires little more than copying-and-pasting paragraphs of text from a legal document onto slides or translating complex legal analyses into a series of one-to-two-word, business-speak bullet points. Worse, many lawyers continue to see the creation of digital presentations not as a "content task" requiring legal expertise but instead as a purely "design task" that should be delegated to junior attorneys and paralegals or, if they can afford it, outsourced to professional designers that specifically service legal clients.¹⁴

The reality is that lawyers and law students are regularly expected to communicate using digital presentations and, more importantly, are expected to accomplish this task themselves. But those lawyers who want to learn to succeed at this task—and law professors who want to teach them how to do it—lack sufficient introductory materials to do so.¹⁵ That is the purpose of this article: to provide an introduction to creating digital presentations for lawyers with a specific focus not only on *what* legal presentations should look like but also *when* lawyers should use digital presentations, *why* they should use them, and the process for *how* they can make them better.

To accomplish this task, the article relies on sources from the robust and evolving academic literature on visual rhetoric in the law. Critically, it

⁹ Ruth Anne Robbins, *Painting with Print: Incorporating Concepts of Typographic and Layout Design into the Text of Legal Writing Documents*, 2 J. ALWD 108, 113 (2004).

¹⁰ James Robinson, *The History of PowerPoint*, BUFFALO 7 (May 22, 2018), <https://buffalo7.co.uk/history-of-powerpoint/>.

¹¹ *Apple Unveils Keynote*, APPLE NEWSROOM (Jan. 7, 2003), <https://www.apple.com/newsroom/2003/01/07Apple-Unveils-Keynote/>.

¹² Gina Trapani, *Google Docs Adds Presentations*, LIFEHACKER (Sept. 18, 2007), <https://lifehacker.com/google-docs-adds-presentations-300825/>.

¹³ See, e.g., Molly Warner Lien, *Technocentrism and the Soul of the Common Law Lawyer Essay*, 48 AM. U. L. REV. 85, 104–05 (1998–1999); Wanda McDavid, *Microsoft PowerPoint: A Powerful Training Tool*, 5 PERSPS. 59, 59–60 (1997).

¹⁴ A simple Google search for "trial graphics" brings up numerous professional graphic designers focused primarily, if not exclusively, on lawyers. Many large law firms now even have in-house graphics teams for this purpose.

¹⁵ There are, of course, more comprehensive textbook-length guides for specific practice areas and topical skills that overlap with this more general overview of legal presentation design. For example, those who wish to learn about trial graphics can refer to Christopher Ritter's *CREATING WINNING TRIAL STRATEGIES AND GRAPHICS*, *supra* note 5, and those who want to better understand the role of images and visuals in law more broadly can refer to Richard K. Sherwin's textbook, *VISUALIZING LAW IN THE AGE OF THE DIGITAL BAROQUE: ARABESQUES & ENTANGLEMENTS* (2011).

also introduces and relies heavily upon the voices of presentation design experts from outside the legal community. These presentation-design experts teach digital presentation skills based on their backgrounds in business, marketing, data visualization, and cognitive science. Although the advice and approach they offer is neither specific to legal audiences nor articulated in uniquely legal idioms, they are targeted at an audience of non-designers asked to share technical knowledge in digital presentation form. This makes their advice particularly valuable to lawyers who simply do not know how to create digital presentations or who generally know how to create digital presentations but also know that they can do the task better, faster, and with far less frustration.

To be clear, this article is neither a complete guide to graphic design for lawyers nor a nuts-and-bolts guide to specific presentation software. It will not magically turn you into a PowerPoint (or Keynote or Google Slides) whiz.¹⁶ It is instead intended as a practical introduction to a creative process for building legal presentations and a primer on the basic skills necessary to complete each step in that process.

The article proceeds in three sections. In section 1 the article lays the foundation for this conversation by exploring why digital presentations are an increasingly important and uniquely effective communication tool for lawyers despite the many critiques of the genre from inside and outside the legal community. Section 2 then offers a start-to-finish, six-step workflow for any lawyer faced with the task of creating a digital presentation. This section relies on (1) the academic and popular literature on the subject, (2) my prior experience as a new lawyer who was asked to convey legal analysis using digital presentations despite not having any formal training, and (3) my current experience as a law professor who has taught legal presentation design to hundreds of law students (both in first-year legal practice courses and upper-class clinical settings). Finally, section 3 concludes by offering some suggestions for the future study and practice of the genre of legal presentations.

1. Why legal presentations?

There is little debate that lawyers across the profession are increasingly using digital presentations to convey legal analysis. For example, according to the 2020 ABA Legal Technology Survey Report,

¹⁶ As Nancy Duarte explains in the context of her own book on presentation design, “This book covers how to create ideas, translate them into pictures, display them well, and then deliver them in your own natural way. It is NOT a PowerPoint manual. You’ll find no pull-down menus or application shortcuts, instead there are timeless principles to ingest and apply. It’s a reference book that you’ll want to open often. This book will teach you ‘why.’” DUARTE, *supra* note 1, at xviii. This article is intended to serve a similar purpose.

17% of trial lawyers reported using presentation software at trial (with 79% responding that PowerPoint is their software package of choice).¹⁷ And almost 36% percent of trial lawyers report using presentation software in their practice. The same is true in many other practice areas where digital presentations have become one of, if not the primary, medium for communicating legal analysis.¹⁸ As a result of this shift, an increasing number of graphic-design consultants specifically serve legal clients, and many large firms employ full-time graphic designers. And yet it is important to remember that lawyers are often asked to create these presentations themselves.

As a young lawyer starting at a large law firm, I was shocked when I was regularly asked to communicate using digital presentations instead of more traditional genres of legal communication. These presentations were geared toward many different legal and non-legal audiences including adjudicators (bankruptcy trustees, judges, and special masters), clients (sales associates, C-suite executives, and clients of clients), other attorneys at my own firm and collaborators at other firms, and even the press. I also hear from my students that they are regularly asked to convey legal analysis using digital presentations in their summer jobs and internships. Some of these students are even asked about digital presentation design at networking events and job interviews. This reality shows that it is important to see digital presentations as a genre of communication that lawyers must learn and that law schools should teach. After all, lawyers are in the advocacy and client business and are therefore subject to their audience's expectations not only about what information to convey, but also the medium or genre in which to convey it.

That said, just because we know that digital presentations are an increasingly important part of the practice does not mean that as lawyers we should ignore the many critiques of digital presentations from both inside and outside the legal community. To the contrary, these critiques—and responding to them—must be the starting place for our discussion. Accordingly, this section considers some of these critiques head-on and argues that although there are certainly times when the use of digital presentations by lawyers may not be the most prudent choice, digital presentations are a useful and increasingly important tool in the contemporary lawyer's toolbox. This is true not only because legal audiences increasingly expect them but also because this genre offers certain distinct advantages over more traditional genres of legal communication.

.....

¹⁷ Stephen Embry, *2020 Litigation & TAR*, AM. BAR ASSOC. (Nov. 30, 2020), https://www.americanbar.org/groups/law_practice/publications/techreport/2020/litigationtar/.

¹⁸ See *infra* section 2.1.

1.1. The blessing and curse of bullet points

The first and often loudest critique of digital presentations is that they are too conclusory and, as a result, stifle creativity and inhibit deep thinking. As Franck Frommer colorfully put it in his book, *How PowerPoint Makes You Stupid*, the so-called “bullet-point” rhetoric common to many digital presentations “favors a mode of communication in which words seem emptied of any substance.”¹⁹ One prominent member of this school of thought is Amazon founder Jeff Bezos who famously banned the use of PowerPoint at internal company meetings replacing them with “six-page memo[s] that[] [are] narratively structured with real sentences, topic sentences, verbs, and nouns.”²⁰ At the beginning of each meeting, participants are given thirty minutes to read the memos and then, and only then, the meeting can begin.²¹ The reason for this approach is perhaps that digital presentations are simply too conclusory and therefore not suited to conveying rich, nuanced, and complex analysis.²²

Similar critiques have been offered by top military commanders such as Former Secretary of Defense James Mattis who opined that “PowerPoint makes us stupid”²³ and former National Security Advisor H.R. McMaster who publicly argued that digital presentations are “danger[ous] because [they] can create the illusion of understanding and the illusion of control [because] . . . some problems in the world are not bullet-izable.”²⁴ Even Steve Jobs, who was famous for his use of digital presentations during keynote speeches to the media and customers, once exclaimed, “I hate the way people use slide presentations instead of thinking. People confront problems by creating presentations. I want them to engage, to hash things out at the table, rather than show a bunch of slides. People who know what they’re talking about don’t need PowerPoint.”²⁵

Arguably the loudest critic of digital presentations in this vein is Edward Tufte.²⁶ Tufte is a professor emeritus of political science,

19 FRANCK FROMMER, *HOW POWERPOINT MAKES YOU STUPID: THE FAULTY CAUSALITY, SLOPPY LOGIC, DECONTEXTUALIZED DATA, AND SEDUCTIVE SHOWMANSHIP THAT HAVE TAKEN OVER OUR THINKING* loc 851 (Kindle ed. 2012) (e-book).

20 Carmine Gallo, *Jeff Bezos Banned PowerPoint in Meetings. His Replacement Is Brilliant*, INC., (Apr. 15, 2018), <https://www.inc.com/carmine-gallo/jeff-bezos-bans-powerpoint-in-meetings-his-replacement-is-brilliant.html>.

21 *Id.*

22 *See id.*

23 Elisabeth Bumiller, *We Have Met the Enemy and He Is PowerPoint*, N.Y. TIMES (Apr. 26, 2010), <https://www.nytimes.com/2010/04/27/world/27powerpoint.html>.

24 *Id.*

25 Geoffrey James, *The Real Reason Steve Jobs Hated PowerPoint*, INC. (Feb. 5, 2020), <https://www.inc.com/geoffrey-james/steve-jobs-hated-powerpoint-you-should-too-heres-what-to-use-instead.html> (emphasis added). As James notes, Steve Ballmer, the former CEO of Microsoft, has offered similar critiques.

26 *See* Stabler, *supra* note 1, at 179.

statistics, and computer science at Yale who travels the country and the world presenting on the most effective ways to visualize data.²⁷ A common theme in his lectures and writings is that the reductive nature of PowerPoint and other digital presentation tools is not just unhelpful, it is dangerous. From his viewpoint, digital presentations reflect a “distinctive, definite, well-enforced, and widely-practiced cognitive style that is contrary to serious thinking.”²⁸ In his view, PowerPoint presentations “too often resemble a school play[—]very loud, very slow, and very simple.”²⁹ And, among his many other criticisms of the genre, he argues that they have “low spatial resolution” (the fact that only a limited amount of information can be displayed at any moment) and use unhelpful “rapid temporal sequencing” (the fact that the viewer must take in individual slides one after the other without sufficient time or opportunity to process or think in less structured ways).³⁰ Worst of all in Tufte’s view, the over-reliance on bullet points leads to “generic, superficial, [and] simplistic thinking” which has real world implications.³¹ He even goes so far as to argue that the use of PowerPoint was one of the causes of the crash of the Space Shuttle Challenger because the “[m]edieval . . . preoccupation with hierarchical distinctions” in PowerPoint led to critical and ultimately fatal mistakes.³²

This critique—that digital presentations are somehow less substantive or overly reductive, and as a result less valuable—is also present in the law. “Words” have long been considered the “lawyer’s primary tool.”³³ As a result, as legal documents become less tied to the detailed textual and narrative conventions of traditional legal writing, there is a concern that they will “create more gloss but less substance in legal discourse,”³⁴ or worse that this use of more visual media will “vitate legal discourse by sacrificing depth for flash—turning legal arguments into memes.”³⁵ As a result, some lawyers argue that there is damage done to legal analysis when lawyering is done by bullet point. This is especially true when lawyers

²⁷ See Joshua Yaffa, *The Information Sage*, WASH. MONTHLY (May/June 2011), <https://washingtonmonthly.com/magazine/mayjune-2011/the-information-sage/>.

²⁸ Stabler, *supra* note 1, at 179 (citing EDWARD R. TUFTE, *THE COGNITIVE STYLE OF POWERPOINT* 26 (2003)).

²⁹ Edward Tufte, *PowerPoint Is Evil*, WIRED (Sept. 1. 2003) archived at http://mcgeef.pbworks.com/f/Wired%2011.09_%20PowerPoint%20Is%20Evil-1.pdf.

³⁰ EDWARD R. TUFTE, *THE COGNITIVE STYLE OF POWERPOINT: PITCHING OUT CORRUPTS WITHIN 2* (2d ed. 2006).

³¹ *Id.* at 5.

³² *Id.* at 10.

³³ Rosman, *supra* note 5, at 70; see also RITTER, *supra* note 5, at 143 (describing lawyers as living in “Wordland” unlike jurors who do not).

³⁴ Elizabeth G. Porter, *Taking Images Seriously*, 114 COLUM. L. REV. 1687, 1774 (2014).

³⁵ *Id.* at 1694.

create “teleprompter presentations” that are “text-dense, bullet-pointed slides on conservative, firm-branded backgrounds with minimal, often simplistic clip art. The presenter often reads the slide text with little elaboration. The text font is often too small for audience members to read,” and the audience’s focus unhelpfully shifts “from the speech and the speaker to the slides.”³⁶ Lawyers also need not look far to find presentations that include overly-complex graphics and diagrams, use unprofessional images and clip art, and which include nothing more than a series of corporate-speak, contextless bullet points. None of these approaches help to convey analysis effectively to legal audiences.

On their face, these critiques may seem compelling. After all, lawyers are trained to craft effective legal analysis in written form by showing the reader the details of the analysis at each step as opposed to relying solely on conclusory assertions. In fact, the failure to show one’s work in legal writing deprives the legal reader of the ability to test the validity of the proposed conclusions based on established analytical paradigms.

And yet these categorical critiques of legal presentations are misplaced for several reasons. First, just because digital presentations *can* be conclusion-based does not mean that they are not analytically rigorous. Digital presentations are a blank canvas on which any level of depth can be conveyed using any number of visual modalities such as words, images, diagrams, audio, and video. As a result, “[t]he software isn’t at fault. It’s an empty shell, a container for our ideas. It’s not a bad communication tool unless it’s in the hands of a bad communicator.”³⁷ Or as legal technologist Dennis Kennedy put it, “[M]ost complaints about PowerPoint are like blaming modern hammers for poorly built houses. It’s not the tool, but how the user uses the tool.”³⁸ That is why studies like the one conducted at Harvard which concluded that “PowerPoint was rated (by online audiences) as no better than verbal presentations with no visual aids” rendering the use of PowerPoint “worse than useless,”³⁹ say far more about presentation designers than they do about the genre writ large. As cognitive psychologist Steven Kosslyn puts it, “[T]here’s nothing fundamentally wrong with the PowerPoint program as a medium; rather, . . . the problem lies in how it is used.”⁴⁰

36 See Dennis Kennedy, *Bite the Bullet Point*, ABA J. (Oct. 1, 2010), https://www.abajournal.com/magazine/article/bite_the_bullet_point.

37 NANCY DUARTE, HBR GUIDE TO PERSUASIVE PRESENTATIONS 95 (2012).

38 Kennedy, *supra* note 36.

39 Geoffrey James, *Harvard Just Discovered That PowerPoint Is Worse Than Useless*, INC. (Aug. 9, 2019), <https://www.inc.com/geoffrey-james/harvard-just-discovered-that-powerpoint-is-worse-than-useless.html>.

40 KOSSLYN, *supra* note 3, at 2.

This problem, at least in the law, is also self-fulfilling. If we as a profession continue to refuse to view digital presentations as a distinct genre of legal communication and fail to train lawyers how to create effective presentations, then poorly organized, poorly researched, and poorly designed presentations will not just happen, they should be expected. But there is another way. As described in *infra* section 2, a digital presentation that is cognizant of its purpose and audience and consciously employs consistent substantive and stylistic conventions can simultaneously convey conclusions as well as the reasons for reaching those conclusions when required—at times even more effectively than narrative text.

The second reason that this critique is misplaced is that the conclusion-based nature of *some* legal presentations actually makes them more valuable communicative tools to lawyers, not less. As Ellie Margolis explains, this is nothing new when it comes to emerging technologies:

Each new writing technology—the printing press, the typewriter, the computer—brought new concerns about the value and credibility of texts they produced. Each new development raised concerns about whether writers would make more errors, and lose clarity, precision, and rigor-ousness. Yet as each new technology took over and became the norm, people learned to trust and depend on them until they became . . . inte-grated into our daily lives; it is difficult to imagine writing without them.⁴¹

The most recent example of this shift in how lawyers communicate was the transition from formal memoranda to informal memoranda prepared for and sent by email. As Kristen Tiscione explained in relation to that transition, the more conclusion-based medium of email memoranda changed the underlying message as compared to traditional formal memoranda because “new technologies act as extensions of man that have ‘psychic and social consequences’ [and] ‘[a]s they amplify or accelerate existing processes’ they change ‘designs or patterns’ of thought.”⁴² And yet, different did not mean less effective. “If an attorney is competent, the analysis will be competent regardless of differences in medium, pace, and pattern of thought.”⁴³ Although “the memorandum and the email are different, they accomplish the same goal, leading to the same ultimate conclusion” and they do so “without the loss of any significant information.”⁴⁴

⁴¹ Margolis, *supra* note 6, at 2.

⁴² Kristen Konrad Robbins-Tiscione, *The Rhetoric of Email in Law Practice*, 92 OR. L. REV. 101, 102 (2013) (citing MARSHALL McLuhan, *UNDERSTANDING MEDIA* 7 (1964)).

⁴³ *Id.* at 116.

⁴⁴ *Id.* at 115 (emphasis omitted).

More than that, the idea that lawyers are not in the business of conclusion-based communication is simply not true. Trial lawyers are required to make their case in great detail, but they are also required to give opening statements that preview key evidence for judges and juries. Transactional lawyers are required to draft complex contracts and agreements but are also called upon to first prepare memorandums of understanding that memorialize high-level agreements. And regulatory lawyers are tasked with not only reviewing and analyzing lengthy pieces of legislation, they are also responsible for providing actionable summaries of specific portions for their clients and colleagues.

The same is true with digital presentations. The ability to convey a set of conclusions—along with the justifications and data behind those conclusions when necessary—without requiring the time-consuming task of putting those conclusions into narrative prose is a feature, not a bug of the genre. As lawyers learned from the transition to legal email memoranda there is “growing client demand[] for quick response time and simple, straightforward advice.”⁴⁵ Digital presentations are another effective way to provide legal analysis or supplement traditional legal documents. This is not to say that digital presentations can always be created quickly or that they are always the best communicative choice. But by the same token, the mere fact that they can and sometimes do offer conclusions should not disqualify them as a valid communication tool. Conclusion-based genres of communications are critical tools in the lawyer’s toolbox, and they need not be any less rigorous in the analysis that underlies them.

1.2. The visual nature of digital presentations

A separate yet related critique often made against digital presentations is that because of their visual nature, they push the limits of appropriate modalities for legal communication. This is what Elizabeth Porter calls the “stylistic straitjacket”⁴⁶ of legal analysis; namely, that traditionally “text typically is the starting point and ending point”⁴⁷ of legal documents, a reality demonstrated by, among other examples, the exclusion of images from legal documents when displayed on commercial research databases like Westlaw and LexisNexis.⁴⁸ For some this argument is little more than nostalgia—this is not how it has always been done—

⁴⁵ Kristen Konrad Robbins-Tiscione, *From Snail Mail to E-mail: The Traditional Legal Memorandum in the Twenty-First Century*, 58 J. LEGAL EDUC. 32, 34 (2008).

⁴⁶ Porter, *supra* note 34, at 1690.

⁴⁷ *Id.* at 1690 n.11 (quoting Ronald K.L. Collins & David M. Skover, *Paratexts*, 44 STAN. L. REV. 509, 534 (1992)).

⁴⁸ *Id.* at 1691.

but for others the critique is more pointed. They argue that non-textual modalities may “mislead and confuse” audiences because, among other reasons, the “legal uses of images rely on the ability of images to persuade without seeming to persuade.”⁴⁹

But, as Porter wrote in 2014, “To rising generations of young lawyers, images are the vernacular of modern communication” and this shift is the result of “[t]echnological advances [that] have opened the door to integrating video, audio, and other technology into” legal documents.⁵⁰ Seven years later this is even more true. And as Ruth Anne Robbins and Steve Johansen conclude, “the question of whether visuals should be used in legal documents has been asked and answered,”⁵¹ and “[v]irtually all scholars who have examined the question conclude that visuals make legal documents more persuasive.”⁵²

For lawyers, visuals serve a number of different functions.⁵³ For example, “documentary visuals” that are evidentiary in nature show the audience something that exists in the world as opposed to just forcing the audience to take the author’s word for it,⁵⁴ and “analytical visuals” “help to explain” legal analysis and provide organizational structure by helping make clear “difficult or ambiguous concepts.”⁵⁵ This makes sense. Why would a lawyer present the complex, intertwined structure of a pending transaction in words alone when a flow chart depicting the relationship between various agreements is so much easier to see and understand? Why would a lawyer in a copyright dispute not show opposing counsel the illegally reproduced image and the original image side-by-side as opposed to making a conclusory statement that the two images are the same? Why would a trial lawyer tell a jury what a key witness said when they can show the text of the actual deposition transcript, or better yet show a video clip of the witness speaking the words? Simply put, lawyers explain and

⁴⁹ Rebecca Tushnet, *Worth a Thousand Words: The Images of Copyright*, 125 HARV. L. REV. 683, 696 (2012). Michael D. Murray also discusses the ethics of using visuals in law in depth:

The power of visual rhetorical devices to communicate comes bundled with a very real potential for harm: while the devices can communicate powerfully on an intellectual and emotional level, they also can be manipulated to deceive. Visual media are ethically neutral. There is nothing inherently deceptive about a particular visual medium, but the ethics of the advocate using the visual medium are immediately implicated by the decision whether or not to employ a visual form of communication in the particular rhetorical situation of the case.

Michael D. Murray, *The Ethics of Visual Legal Rhetoric*, 13 LEGAL COMM. & RHETORIC 107, 111 (2016).

⁵⁰ Porter, *supra* note 34, at 1693.

⁵¹ Johansen & Robbins, *supra* note 6, at 62.

⁵² *Id.* at 61.

⁵³ Steve Johansen & Ruth Anne Robbins offer a helpful taxonomy of legal images. See Johansen & Robbins, *supra* note 6, at 66–67.

⁵⁴ *Id.* at 63–64.

⁵⁵ *Id.* at 67.

persuade—and when doing so they ought to use the best tools available to them to accomplish that task.

In fact, digital presentations take the benefits of visual rhetoric and extend them a step further by allowing a lawyer to jump back and forth seamlessly between different media and modalities *in the same document*. One slide might include statutory text (or a bullet-point summary). Another slide an image. A third slide an audio clip. A fourth slide a video. And a fifth slide a mix of all four. It is this multi-modal approach that really demonstrates the power of digital presentations. As Chris Anderson, the Curator of TED, puts it well: “Often the best explanations happen when words and images work together. Your mind is an integrated system. . . . If you want to really explain something new, often the simplest, most powerful way is to show and tell.”⁵⁶ This is of course particularly true in a profession where time is of the essence to both client and lawyer (not to mention often charged by the tenth of an hour).

To be sure, digital presentations are not perfect legal tools. This article does not attempt to argue otherwise. But just because the quality or strategic benefit in particular circumstances is suspect, that does not mean that lawyers gain no benefit from using digital presentations—whether requested by their audiences or not. As a result, lawyers should learn to communicate using digital presentations. As presentation expert Nancy Duarte explains, “Making bad slides is easy, and it will negatively impact your career.”⁵⁷ It is therefore necessary not only to “[i]nvest in your slides, but invest in your own visual skills as well.”⁵⁸ Section 2 provides a concrete approach for doing just that.

2. The legal presentation playbook

Lawyers often fear the blank page. The same fear exists for lawyers tasked with creating digital presentations albeit in the form of a fear of the blank slide. In fact, this fear is often magnified when creating digital presentations because the effectiveness of these presentations is judged not solely on their content but also on their organization, design, and aesthetic quality. I propose that the best response to this fear is process—a systematic, intentional, and repeatable workflow to move from idea to final presentation no matter one’s purpose, practice area, or level of technical expertise. This section offers just such a process for legal presen-

⁵⁶ CHRIS ANDERSON, TED TALKS: THE OFFICIAL TED GUIDE TO PUBLIC SPEAKING 115 (2016).

⁵⁷ DUARTE, *supra* note 1, at 3.

⁵⁸ *Id.*

tation design. To be sure, the process it outlines is not *the* approach to creating legal presentations, but it is certainly *one* way that is efficient, effective, research-based, and battle-tested.

The process includes six steps:

- Step One is to identify the specific **purpose and audience** (or purposes and audiences) for both the digital presentation and any other document or oral presentation that the digital presentation supplements or summarizes.
- Step Two is to research, analyze, and outline the **content** (the law, the facts, and the application of the law to those facts) for the presentation.
- Step Three is to transform the content from Step Two into discrete visual units using a **storyboard** and **common slide types** with an eye toward a presentation that is organized, convincing, and visually meaningful in light of the content outlined in Step Two and the purpose(s) and audience(s) identified in Step One.
- Step Four is to create a “**presentation brand**” that uses color, typography, images, transitions, and animations in intentional and consistent ways that specifically respond to the purpose(s) and audience(s) identified in Step One.
- Step Five is to convert the storyboard from Step Three into **slides** in ways that are consistent with the presentation brand in Step Four using presentation software.
- Step Six is to **edit, strengthen, and streamline** the slides created in Step Five by refocusing on the purpose(s) and audience(s) of the digital presentation identified in Step One and the content from Step Two.

On its face, this six-step process should not seem particularly foreign to those accustomed to crafting legal analysis. It is intentionally based on the traditional approach to drafting and creating other legal documents: identify the purpose and audience, outline the content, draft the content, integrate that content into the form and format the audience expects, and edit, edit, edit. At the same time, this process is distinct from other genres of legal communication in its points of emphasis and, in some cases, the different skills necessary to accomplish each step.

To be clear, this approach is not simply about making presentations that look better (although following this advice will result in better-looking presentations). The objective is crafting presentations that better serve the lawyer’s purpose(s) for their audience(s). This is an important distinction often lost on new legal presentation designers who either focus

so much on the aesthetics that the content is lost, or do a thorough job preparing the content but do not think critically about how to display that content in compelling and intentional ways. This process seeks to bridge that gap. The key to effective presentation design is finding the right balance between content and design elements so that the sum is greater than the whole of its parts. As one presentation design expert, Jonathan Schwabish, puts it, “[C]reating better slides is not about ‘making things pretty,’ but about recognizing how to communicate and how conscious—and oftentimes simple—design choices can help you do so.”⁵⁹ As a result, as another recognized presentation design expert Garr Reynolds notes,

[P]reparing a presentation is an act requiring creativity . . . [It] is a “whole-minded” activity that requires as much right-brain thinking as it does left-brain thinking. . . . [W]hile your research and background work may have required much logical analysis, calculation, and careful evidence gathering using left-brain thinking, the transformation of your content into presentation form will require that you exercise much more of your right brain.⁶⁰

Finally, although digital presentations require lawyers to use digital software, learning how to use that software is a relatively small part of the process. Most digital presentations that lawyers create can and often are built using a very limited set of tools: text, shapes, automatic diagrams (called “SmartArt” in PowerPoint) that put words in shapes, and images. That’s it. Although learning the intricacies of specific presentation software will not hurt a lawyer who aspires to create better presentations, it will not be discussed in the sections that follow for two reasons. First, believing that one can create better legal presentations just because one knows more about how to use a particular software package is like believing that one can write better briefs simply because one knows more words (or worse, because they know more about Microsoft Word). The truth is quite different. It is important to think of presentation design software as a tool to execute a vision that the lawyer should be able to sketch on a post-it note or describe orally to a colleague. Knowing how to transform that vision using software is far less important than having the tools to come up with the vision in the first place. Second, presentation design software has become more intuitive and user-focused in recent years and, as a result, a lack of experience with the software really is no longer the primary gating item to the creation of good legal presentations.

⁵⁹ See JONATHAN SCHWABISH, *BETTER PRESENTATIONS: A GUIDE FOR SCHOLARS, RESEARCHERS, AND WOKNS* 3 (2017).

⁶⁰ GARR REYNOLDS, *PRESENTATION ZEN* 32 (2d ed. 2012).

If necessary, there are many places to find good advice on these ever-changing software packages including books, blogs, and online videos. Lawyers must keep their eyes on the real challenge: learning a tailored creative process for building digital presentations in the first place.

2.1. Step one: Purpose(s) and audience(s)

Step One of the digital presentation creation process is to identify the purpose and audience for the presentation. Nancy Duarte refers to this as identifying the presentation’s “transformation.”⁶¹ Before beginning, the presentation creator must “map out that transformation—where your audience is starting, and where you want people to end up.”⁶² This admonition should be familiar to lawyers as the starting place for all forms of legal communication. In crafting legal analysis, it is never enough to know just the law and facts of a case. It is just as important to understand the purpose and audience for that legal analysis. That is why lawyers start every assignment with two questions: (1) *what* information am I trying to convey and (2) *to whom* am I trying to convey it.⁶³ Digital presentations are no exception. Just like written and oral legal analysis, digital presentations can be predictive or persuasive, can be targeted at legal or non-legal audiences, can be formal or informal, and can be detailed or high-level. Determining the audience and purpose is an integral first step.

In fact, this step is arguably more important and more nuanced than identifying the purpose and audience for other forms of legal communication for two reasons. First, although some legal presentations are freestanding documents that have a singular, clearly identifiable purpose, legal presentations are often tied to other documents or oral speeches that have their own distinct audiences and purposes. It is critically important not to conflate the purpose and audience for the digital presentation and the purpose and audience of the work product that the presentation accompanies, summarizes, or supplements.

For example, when a digital presentation accompanies an oral speech it is particularly important not to create text-heavy slides that compete with the speaker. Your audience will “either listen to you speak or read your slides—they won’t do both simultaneously (not without missing key parts of your message, anyway).”⁶⁴ The purpose of the digital presentation deck

⁶¹ DUARTE, *supra* note 37, at 19.

⁶² *Id.*; see also KOSSLYN, *supra* note 3, at 4 (“A presentation must be built from the outset around your takehome message; every aspect of the presentation should be relevant to what you want the audience to know and believe when they walk out the door.”).

⁶³ See, e.g., ALEXA Z. CHEW & KATIE ROSE GUEST PRYAL, *THE COMPLETE LEGAL WRITER* 5–7 (2016).

⁶⁴ DUARTE, *supra* note 37, at 113; see also KOSSLYN, *supra* note 3, at 6; SCHWABISH, *supra* note 59, at 65.

is therefore not to repeat what the speaker is saying (and thereby distract the audience) but rather to contextualize the oral presentation and orient the audience to what is being discussed, why it is being discussed, the key takeaways from that discussion, and what will be discussed next. By contrast, when a digital presentation is primarily a stand-alone document that the audience is expected to review on its own, the digital presentation may need to use more words in order to make both its arguments and conclusions explicit.

The second reason that identifying the purpose and audience of a presentation specifically is so important is that the same digital presentation can serve very different purposes and audiences at different times. For example, a single digital presentation might be used to supplement a live oral presentation, then later be shared by email with the same audience, who then forward it on to others who were not present for the initial presentation. These multi-purpose presentations are uniquely challenging. For example, a lawyer who plans to use a digital presentation as part of an oral speech and then share those slides after the fact needs to make sure that the slides assist in the delivery of the presentation and can stand alone for the audience after the fact.

Several examples from different practice areas illustrate the interplay between these two dynamics and how they can (and should) impact the presentation-creation process.

Tax attorneys.⁶⁵ For outside counsel or legal consultants who provide tax recommendations to clients on new transactions, it is common that the first deliverable created is a digital presentation. This digital presentation is not created in addition to another written deliverable; it is the written deliverable consumed by its audiences. It does not accompany a formal memorandum nor is it presented orally by its drafters. The digital presentation is typically created by consulting with attorneys from each relevant jurisdiction who craft textual bullet points about the tax consequences in their jurisdictions as well as a team of attorneys responsible for managing the project and making the ultimate recommendations that are proposed in the form of visual diagrams. The specific format and icons used in these visual diagrams are standard in the industry and therefore easy for those in the field to follow. The audiences for this digital presentation are often relevant stakeholders at the client, and corporate attorneys (either in-house counsel, outside counsel, or both) who are responsible for creating the transactional documents necessary to complete the proposed deal. The purposes of these digital presentations are (1) to make sure that all of these different audiences agree on the approach and its tax conse-

.....
⁶⁵ This description is based on discussions with an international tax planning attorney.

quences, and (2) to make sure that there are no unforeseen jurisdictional tensions or misunderstandings before the deal documents are drafted. After the presentation has been reviewed individually, there is often a meeting between supervisory stakeholders to confirm that no significant changes are necessary (and if there are, a new presentation is created). Then after the final decisions are made, the tax lawyers use the presentation to put together a formal written opinion or memo documenting the expected tax consequences of the transaction. Unlike the digital presentation that helps document the decisionmaking process, the memo that follows is primarily geared toward explaining the expected tax consequences of the transaction to the client and its financial auditors.

Presentation to a litigation client. For a lawyer asked to meet with a client and present information or recommendations, a digital presentation often serves multiple purposes and audiences. Take, for example, a face-to-face meeting or videoconference with a tenant about an ongoing dispute with their landlord. The audience for that meeting is the client in the room, and the purpose of the presentation in that moment is to help the lawyer walk through the client's options, make recommendations about how to proceed, and answer any questions in real time. It also allows the attorney to display relevant evidence about the case as they are presenting. For this purpose, the digital presentation need not (and in fact, should not) contain everything the attorney plans to say aloud. After all, the point of having this meeting is to give oral advice, not read that advice off a screen. But, if after the meeting the lawyer shares those slides with the client, they serve a different purpose and audience. The digital presentation now must emphasize the legal elements of the cause of action and crystalize the relevant choices the client needs to make in a way that is understandable without the lawyer present. More than that, unlike the use of the presentation in the meeting, the presentation now needs to self-narrate. As a result, the digital presentation requires more detail given that the client will have an opportunity to view it without the ability to ask questions in real time.

Policy advocate. A third example is an attorney who works for a non-profit who is meeting with a legislator to lobby for changes to a statute. In this situation, the attorney might choose not to use a digital presentation at all during the meeting in order to encourage a more free-flowing conversation. The only document the lawyer might bring into the meeting is a page of notes for personal use including, for example, statistics that the lawyer hopes to convey. But the lawyer might nevertheless choose to create a short digital presentation (perhaps a single-page infographic) to print out and leave with the legislator or legislative staffer after the meeting. In this situation, the digital presentation's purpose is related to

but separate from the notes the lawyer brought into the meeting. Instead of specific details, the digital presentation seeks to quickly communicate the high-level summary of what is wrong and how to fix it. The audience is also significantly wider than the single person with whom the lawyer met because the infographic presentation can be shared. This digital presentation therefore must be geared toward those who were not part of the face-to-face meeting. Although the research and preparation for both the meeting and the digital presentation are the same, the audience and purpose are different.

Bankruptcy lawyer.⁶⁶ Bankruptcy attorneys also use digital presentations in several systematic ways including for boards of directors, creditor groups, and hearings. As one bankruptcy lawyer explains it,

[B]ankruptcy attorneys use digital presentations to support, clarify, and frame important decisionmaking at various points in a restructuring process. In counseling a board of directors of a distressed company, digital presentations also serve as a vital tool to create a record of the board's deliberations, which is intended to preserve the board's ability to benefit from the business judgment rule.

It is important to get the process right and “board [presentations] are *the* way to show that the board complied with its fiduciary duties. As a result, there are a lot of conversations about what text should be in the [presentation] deck and what should be voiced over.”

Patent attorneys. A final example is patent attorneys. Patent attorneys often use digital presentations and other forms of graphics in briefs and at trial to display information and images to the judge and the jury.⁶⁷ These demonstratives are essential to the case because they often show the patent application and the invention at issue. And yet when those same patent attorneys argue a legal issue on appeal to the Federal Circuit they rarely do so with any demonstratives at all. The reason for this shift is that the audience is now judges who have the relevant diagrams available to them in briefs as opposed to a jury who does not have that benefit.

And these are just a few representative examples. Together what they demonstrate is the importance of identifying not only the purpose and audience for the presentation but also the purpose and audience of any document the presentation supplements or accompanies.

Before moving on though, it is equally important to emphasize who the audience of a legal presentation is not: the lawyer creating the

66 This description is based on discussions with a bankruptcy attorney.

67 This description is based on discussions with a patent attorney.

presentation. Digital presentations are not teleprompters. Using digital presentations as teleprompters rarely if ever supports the lawyer’s purpose or audience.⁶⁸ Requiring (or even allowing) the audience to read along while the presenter reads from slides is a notoriously bad approach.⁶⁹ As Guy Kawasaki, former Chief Evangelist at Apple and recognized expert in presentation design, colorfully put it,

If you start reading your material because you do not know your material, the audience is very quickly going to think you are a bozo. They are going to say to themselves “This bozo is reading his slides. I can read faster than this bozo can speak. I will just read ahead.”⁷⁰

This is not to say that presentations focused on conveying information to the audience do not help a lawyer presenting orally. After all, a list of bullet points that primarily serve the audience still can be good reminders of the key concepts the lawyer wants to cover and in what order. But this reality should not negate the rule: digital presentations are not teleprompters. Instead they are primarily if not exclusively created for the benefit of the audience. And, for the reasons discussed above, it is essential to start with who that audience is and what purpose *the presentation* specifically serves.

As a result, to accomplish this first step, one effective approach is asking five simple questions before designing any legal presentation:

1. What is the digital presentation? Is it a deliverable in and of itself or is it adjacent to another deliverable (oral presentation, meeting, written memo, etc.)? If it accompanies other deliverables, what *unique* role does the presentation play?
2. Who is the primary audience for the digital presentation (just those in a meeting, those after the fact who were not present, perhaps anyone with whom the client shares the presentation)? Are there other audiences that also should be accounted for?
3. When is the digital presentation going to be reviewed (in the moment, after the fact, years later, all of the above)?
4. Why is the audience viewing the digital presentation (to make a decision, to understand what happened, to be persuaded, to put in writing the decisionmaking process)?

⁶⁸ DUARTE, *supra* note 37, at 96 (“[D]on’t project your entire document when you speak. No one wants to attend a plodding read-along. It’s boring and people can read more efficiently on their own, anyway.”).

⁶⁹ *See id.* at 95–96.

⁷⁰ REYNOLDS, *supra* note 60, at 244.

5. Where is the audience going to view the digital presentation (on a projector screen, on their own computer, on a cellphone, or in print)?

These questions help separate the purpose and audience for the presentation from any other purpose(s) or audience(s). After answering these questions—and only after answering these questions—is a lawyer ready to begin the content-creation process.

2.2. Step two: Content

The next step is both the most important step in the presentation creation process and often the most time consuming: content creation. And yet this step is also the easiest to explain to lawyers and law students. That is because this step is no different than that of any other legal document or legal deliverable. The same tools and approaches of legal writing, research, and analysis apply.

Yet the most common challenge when lawyers are asked to develop content for a digital presentation is not a lack of skills, it is a failure to use those skills because one is “just making a presentation.” Put another way, too many presentation creators (lawyers and law students included) assume that just because analysis is conveyed in presentation form that they can simply open presentation software and start typing instead of using the research and analytical tools they have developed over years of education and legal practice.⁷¹ This is a major mistake. Just because a digital presentation can be shorter, more visual, or more conclusion-oriented does not mean that the hard work of legal analysis or argument can be sidestepped.⁷² After all, if a legal presentation is not well analyzed, is based on the incorrect law, or is simply too difficult to follow, no level of typography, graphic design, or flashy transitions can save it. A legal presentation is only as good as its content.

To be fair, not every digital presentation starts from scratch. Many legal presentations are created *from* or *based* on other work product (for example, a memo, a prepared argument, or a research email). In those circumstances this content step is substantially complete prior to the creation of the digital presentation and as a result may require only filling in gaps or reformulating this content for a different audience or purpose. That said, the process of creating a digital presentation from another legal

71 See SCHWABISH, *supra* note 59, at 11 (“When you begin creating your presentation, try to refrain from immediately opening the computer and starting on a slide deck.”).

72 See DUARTE, *supra* note 37, at 47 (“Because presentation programs such as PowerPoint are visual tools, we often jump too quickly into visually expressing our idea when we use them—before we’ve spent enough time arranging our thoughts and crafting our words.”).

document often identifies significant gaps in research and analysis that require further content development. This alone is one of the reasons that I ask my first-year law students to create digital presentations during their first semester right after they turn in the first draft of a legal memo. It provides an opportunity to learn to convey analysis in a new genre of legal communication but it also helps illustrate what is missing from a student's analysis before turning in their next written memo draft.

If, however, the presentation is the first time the lawyer or law student is engaging with the relevant law and facts for a particular legal question, this content step requires the same level of detailed research and analysis required of any other genre of legal communication. Perhaps more. That is because although a presentation may only highlight or make explicit a piece of the analysis or argument, the audience trusts that the content is based on the same rigorous analysis necessary for all legal communication. For example, unlike a legal brief which walks through the facts and analysis of a prior case in written detail before using analogical reasoning to argue that the prior case is similar to or different from the current case, a presentation might only highlight the conclusion of that analogy. As a result, the audience has to take the presentation's conclusion as valid even if each step in that analysis is not shown explicitly—and that analysis must therefore be correct. Simply put, the content stage cannot be ignored, and the importance of doing this analysis and doing it well *prior* to starting a legal presentation cannot be overstated.

2.3. Step three: Storyboard using slide types

At Step Three, the lawyer or law student creating a digital presentation begins to move from content creation to designing the display of that content. This is an extremely important step because it is the moment when the work of creating content and identifying the purpose and the audience with precision come together and are ready to be transformed into a presentation. Although there are surely many ways to accomplish this step, many design experts recommend bridging this gap from content to design using a technique known as “storyboarding” using slide types. For the reasons discussed below, this approach allows for a systematic and effective transformation of ideas into discrete visual units.⁷³

2.3.1. How and why to storyboard

A storyboard is nothing more than a visual outline. Like an outline, a storyboard helps a presentation creator “clarify what [they] want to say

.....
⁷³ See, e.g., REYNOLDS, *supra* note 60, at 95.

and how [they] want to say it.”⁷⁴ Much has been written about effective storyboarding techniques in different fields such as filmmaking,⁷⁵ visual analytics,⁷⁶ and software design.⁷⁷ It has also been mentioned by legal authors as an effective technique for building legal briefs.⁷⁸ At its core though, the idea of storyboarding is not complicated: it is a “short graphical depiction of a narrative.”⁷⁹

The tools for creating storyboards can be analog (3x5 cards or post-it notes) or digital (outlining software or the presentation software itself). Whatever the tool, the idea is the same: brainstorm one idea per slide and for each slide, outline how that idea will be visually displayed.⁸⁰ This allows ideas to be “captured, sorted, and rearranged as needed.”⁸¹ In this way, the process of storyboarding is flexible and can accommodate lawyers who prefer to brainstorm in more visual ways or in more word-based formats. For those with a more visual bent, a storyboard can consist of a set of post-it notes or index cards with some basic sketches of not only what information is going to be covered but how it will be depicted visually. For those less predisposed to visuals the easiest way to start is with that same stack of post-it notes or index cards. But instead of sketches, each card or post-it should include a few words or even a sentence about what content will be covered on the slide and a brief description of how that content might be displayed when it is moved into presentation software. Storyboarding also works well for lawyers writing in teams because different team members can quickly brainstorm individually before coming together to find the best narrative arc, or the group can together build that arc under the leadership of a senior team member.

How detailed should a storyboard be? On the one hand the storyboard need not include the final language or design for each slide (“[t]his is an ideation phase”⁸²). Rather a description of what needs to be covered and how it might be illustrated is plenty. On the other, a single

⁷⁴ DUARTE, *supra* note 37, at 124.

⁷⁵ *Id.* at 123; *How to Make a Storyboard for Video and Film: The Definitive Guide*, STUDIOBINDER (July 12, 2019), <https://www.studiobinder.com/blog/how-to-make-storyboard/>.

⁷⁶ See, e.g., Rick Walker, et al., *Storyboarding for Visual Analytics*, 14 INFORMATION VISUALIZATION 27 (2015).

⁷⁷ See, e.g., Truong, Hayes & Abowd, *Storyboarding: An Empirical Determination of Best Practices and Effective Guidelines*, PROCEEDINGS OF THE SIXTH CONFERENCE ON DESIGNING INTERACTIVE SYSTEMS 12 (2006).

⁷⁸ See, e.g., STEFAN H. KRIEGER & RICHARD K. NEUMANN, *ESSENTIAL LAWYERING SKILLS: INTERVIEWING, COUNSELING, NEGOTIATION, AND PERSUASIVE FACT ANALYSIS* 188 (2015).

⁷⁹ DUARTE, *supra* note 37, at 123 (“Basic storyboarding isn’t hard, and it saves you more time than it takes.”); Truong, *supra* note 77, at 12.

⁸⁰ ANDERSON, *supra* note 56, at 115, 116 (“The key to avoiding [bad slides] is to limit each slide to a single core idea.”); DUARTE, *supra* note 37, at 123 (“Storyboard [o]ne [i]dea [p]er [s]lide.”)

⁸¹ DUARTE, *supra* note 1, at 28.

⁸² DUARTE, *supra* note 37, at 123.

word or conclusory phrase like “elements” or “recommendations to the client,” is often less helpful because it really does not allow the lawyer to think critically about what content will be portrayed to the audience and for what purpose. The only way the storyboard will allow the presentation creator to “visualize the sequential movement of . . . content, narrative and the overall flow and feel of the presentation”⁸³ is if it has *some* detail. But too much detail can actually prove an impediment to success. There is at least one study in the field of software development that shows including more detailed sketches at this storyboarding stage does not necessarily make the ultimate product better and can even prove detrimental because creating more detailed designs takes more time and the inclusion of extra detail at this stage may even “impede understanding.”⁸⁴

The key here is that the storyboard is not the final presentation. The storyboard is instead a part of the process to create a final presentation that effectively conveys information visually. Just as “[f]ilmmakers sketch out their shots *before* production begins to make sure they’ll hang together structurally, conceptually, and visually, good presenters use a similar planning process before they sweat over their slides.”⁸⁵ That is because “[a]s you storyboard, you’ll be able to tell immediately which concepts are clunky or overly complex Eliminate them, and brainstorm new ways to communicate those messages.”⁸⁶ Another benefit of storyboarding is that it makes clear what concepts will require multiple slides and what concepts will require just one (or can be excluded altogether). This helps simplify and distill what is displayed and “[s]implicity is the essence of clear communication.”⁸⁷ Ultimately, this process allows the presentation creator to quickly and iteratively work through ideas about what to include, how to include it, and in what order to include it before wasting significant time and effort (not to mention money) in creating intricate slides.

2.3.2. Using slide types

The danger of telling inexperienced presentation creators to just start storyboarding is that they do not have enough context for what typically is included in a legal presentation or what kinds of slides they have at their disposal to tell that story. As a result, they often turn to built-in or firm-mandated templates for guidance. But these templates

83 *Id.* at 125; REYNOLDS, *supra* note 60, at 95.

84 Truong, *supra* note 77, at 16.

85 DUARTE, *supra* note 37, at 123.

86 *Id.* at 125.

87 *Id.* at 128.

provide *design* guidelines—that is, they focus on the visual look and feel of slides—not *content* guidelines—that is, what to include and how to include it. Given that it is always easier to build something if we know the tools and materials we have at our disposal, identifying and describing common slide types helps lawyers avoid feeling that they are truly starting their storyboard from scratch. Many presentation experts use a similar approach albeit with various names for the different slide types. For legal presentations, the three most common categories of slides include (1) guide slides, (2) documentary slides, and (3) content slides. Each category is described in greater detail below.

2.3.2.1. *Guide Slides*

Guide slides are the starting place for any presentation. They are organizational slides that help the audience consume a presentation and direct the audience’s focus on the right things at the right time.⁸⁸ Guide slides do not themselves convey a significant quantity of content to the audience. Instead their primary role is to help the audience consume the content of the presentation and any other deliverable that the presentation accompanies or supplements. Some common guide slides include title slides, header slides, agenda slides, and background slides.

Title slides. Title slides (sometimes called “walk-in” slides⁸⁹) are typically the first slide or “cover” of a digital presentation. They orient the audience to the topic and purpose of the presentation and serve the same role as the subject of an email, the heading for a memo, or the caption of a brief. Title slides can be very simple or very intricate depending on the purpose of the presentation and comfort level of the presentation designer. Especially at the storyboard stage it is important to focus on (1) whether to include a title slide, and if yes, (2) what textual information to display, and (3) what visual elements might provide useful context to that text. Title slides are common in legal presentations but not mandatory. For example, a one-page infographic slide likely will *not* include a Title Slide.

That said, for longer presentations, title slides are important because they are the first opportunity to connect with the presentation audience. Even if we are not supposed to judge a book by its cover, we often do. As a result, it is worth putting some time and thought into title slides at the storyboarding phase and throughout the creation process. In doing so it helps to focus on avoiding the three most common mistakes in crafting

.....

⁸⁸ For example, Jonathan Schwabish refers to these slides as “scaffolding slides.” SCHWABISH, *supra* note 59, at 135 (“The purpose of scaffolding slides is to guide and focus your audience’s attention as you transition from one section to another, and to drive home important points.”). Nancy Duarte refers to these slides as “navigation slides.” DUARTE, *supra* note 37, at 117.

⁸⁹ *See id.*

title slides. First, do not create textual titles that are too detailed (e.g., “A CAREFUL ANALYSIS OF THE MOST IMPORTANT DOCUMENTS OF THE 1,574 DOCUMENTS INCLUDING EMAILS AND WORD DOCUMENTS PROVIDED BY JOHN SMITH OF OUR CLIENT JOHNSON, JOHNSON, AND HIGHLAND LLP”) or not detailed enough (e.g., “HOT DOCUMENTS”)—and when you do, do not use all caps for the reasons discussed in *infra* section 2.4.1. Instead, just like the subject line of a formal memorandum, it is important to include just enough contextual information in the textual title but not so much that the audience ignores the title all together.

Second, do not include too much information in addition to the presentation title. For example, even experienced presentation designers often include a complete business card’s worth of information on the title slide even when the name of the presenter is not even necessary or better yet, the fax number for the lawyer’s office. The rule of thumb here is for the creator to ask: is the audience helped by the inclusion of this additional information on the title slide? If so, include it. If not, exclude it.

Third, use visuals, but make the visuals audience centered, not law firm or lawyer centered. This is a common mistake for legal presentations, perhaps because so many lawyers use firm-based templates. But as the example slides below show, a focus on the firm name as illustrated in Slide 1, distracts from the title of the presentation (the very purpose of the slide) as opposed to elevating it. By contrast, a simple full-screen image along with a clear textual title, as in Slide 2, primes the audience for exactly what the presentation is about as opposed to a title slide that says more about the presenter than the presentation.

Slide 1

Widget Corporation and Thingy Company Merger Plan

Rachel Johnson
Johnson, Johnson & Highland LLP
Cell: (555) 123-4567; Fax: (555) 321-9854
rjohnson@jjhlaw.com
123 J Street, NW
Suite 12A
Washington, DC 20001

Slide 2



Agenda slides. Agenda slides are the next most common type of guide slide. They serve a role similar to roadmap paragraphs, tables of contents, and introductions in other genres of legal writing. They allow the creator to prepare the audience for what is to come and why. That said, not every presentation needs an agenda slide, but the longer and more intricate the presentation, the more helpful it can be. As always, the presentation creator should ask, will my audience benefit from a preview of what's to come? If yes, it is worth including them.

Agenda slides can be designed in a number of different ways (as Slides 3 and 4 below demonstrate). At the storyboard stage, though, it is okay to focus only on putting together the high-level concepts that will be included and some potential ideas for the overall aesthetic.

Header slides. The third type of guide slide is a kind of mix between title slides and agenda slides: "header slides." Header slides are like title

Slide 3

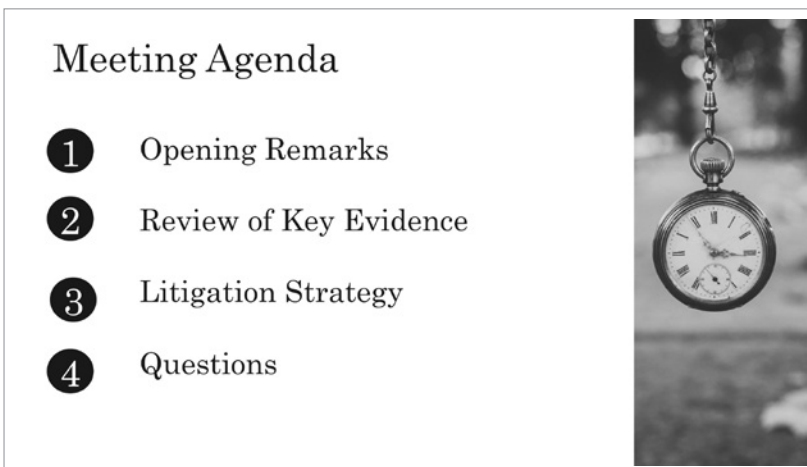

Slide 4



slides for the sections identified in the agenda slide. They serve a similar purpose to point headings in other genres of legal writing. That is, they tell the audience that a new topic is being covered (and sometimes illustrate how that new topic connects to prior or later topics as well). Like agenda slides, not every presentation needs header slides. Yet, especially for longer presentations, they can be particularly helpful for the audience experience whether a presentation is presented orally or reviewed individually.

There are different ways to create header slides as illustrated below in Slides 5 and 6 (words, images, or even versions of the agenda slide). At the storyboard stage it is worth including placeholders for header slides even if they are ultimately omitted for organizational or stylistic reasons. They help order and organize the presentation for the presentation creator and

Slide 5

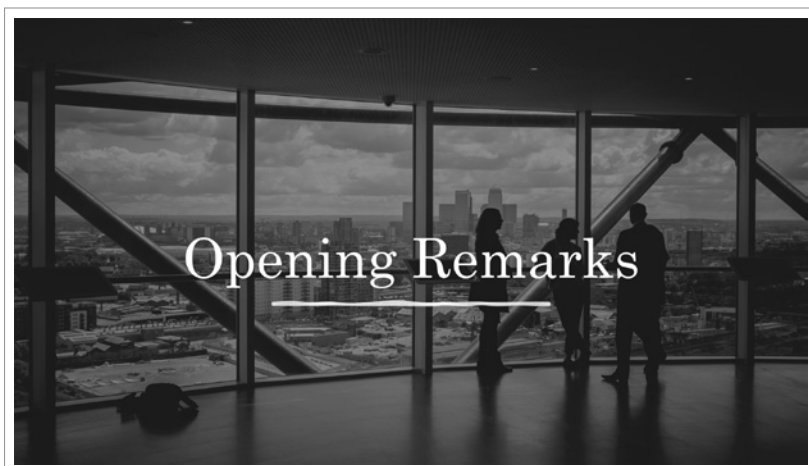

help ground the decisions both about what to include and how to include it.

Slide 6

Meeting Agenda

- ① Opening Remarks
- ② Review of Key Evidence
- ③ Litigation Strategy
- ④ Questions



Background slides. The final type of guide slides are “background slides.” A background slide contains no text and is either completely blank or just a full-screen image. The idea behind background slides is that they tell the audience that it is not time to focus on the digital presentation. It is instead time to turn their focus somewhere else (typically to the speaker). As a result, these slides are used primarily in digital presentations that accompany an oral presentation.

There are two approaches to background slides. One technique for creating background slides is just using blank slides with the background color of your presentation. This signals to live- presentation audiences that it is time to focus on the speaker and only on the speaker. They also benefit the audience by giving them “a vacation from images [to allow them to] pay more attention to [the speaker’s] words. Then, when [the presenter] go[es] back to slides, they will be ready to go back to work.”⁹⁰ Although this is not an approach lawyers tend to use, it can be particularly powerful when presenting orally with slides.

The other kind of background slide is an image slide that primes the audience for what the presenter is saying out loud but which does not require the reader to read or review anything additional. These background slides are similar to “b roll” in a TV show or commercial—they are decorative images that give the audience something appealing to look at as they listen to the presenter but they also allow the presenter to retain the audience’s complete attention.⁹¹ For example, if a lawyer were discussing

⁹⁰ ANDERSON, *supra* note 56, at 116.

⁹¹ Johansen & Robbins, *supra* note 6, at 70.

the protocol for collecting documents in response to a subpoena and needed a backdrop for that discussion, they could use the following full screen image.

Slide 7



2.3.2.2. Documentary Slides

The next category of slides is documentary slides. These slides display extrinsic information, data, or evidence not created by the author. For example, a documentary slide might include a photograph of the location where an alleged crime was committed, a quotation from a public document filed with the SEC, or a video clip of a deposition. Documentary slides often play a very important role in all types of legal presentations—but especially in trials and document-heavy practices. When storyboarding a documentary slide a lawyer need only identify what evidence to display and what if anything they wish to use to help display it.

Slide 8

“I read the company’s 10-K prior to publishing it and confirmed its accuracy.”

- Jim Smith, CFO

Slide 9

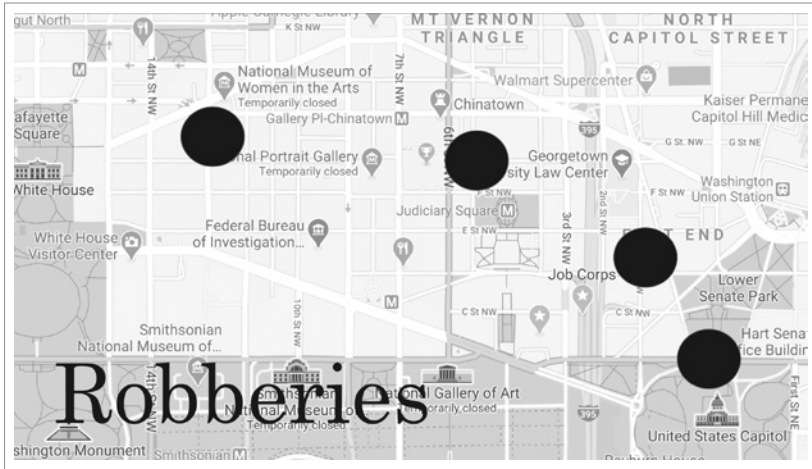

Slide 10

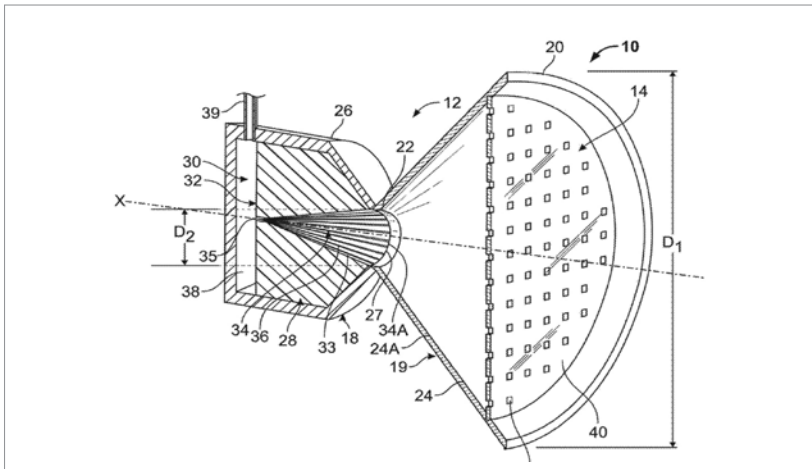

The power and benefits of documentary slides are difficult to overstate. Lawyering is, at its core, evidence-based argumentation and analysis and therefore displaying that evidence is often the most helpful to audiences and, incidentally, the least difficult to create. These slides allow the presentation creator to show the audience as opposed to tell, and all that is typically required to create them is copying-and-pasting the media onto a slide with only minimal additions.

2.3.2.3. Content Slides

The final slide type is content slides. These are the slides that convey independent legal analysis. This often comes in the form of textual bullet points but can also just as often come in the form of diagrams or other pictorial representations of that information or analysis. Although there can be some overlap, the difference between a diagram-based content

slide and a documentary slide is that the diagram-based content slide is created entirely by the presenter whereas a documentary slide is primarily displaying an image that exists in the outside world. At the storyboarding stage, the focus for content slides should be both the information the content slide needs to convey and some high-level thoughts on how visually it might be conveyed. More specifics on how to design these content slides are covered in *infra* sections 2.4 and 2.5.

2.4. Step four: Presentation brand

Step Four in the creation process is to create a visual brand for the presentation. The presentation brand is the set of presentation-wide design elements that provide a cohesive and easy-to-follow look and feel whether the presentation is a single slide or several hundred. Creating a strong, content-responsive, and audience-driven presentation brand is essential because “employing good design techniques is about unifying the various elements on the screen and focusing your audience’s attention on your important points so that they can decide whether or not to buy into your ideas.”⁹²

If this concept is foreign to lawyers, it should not be. A consistent, cohesive, and appealing brand is essential for all legal documents. As Ruth Anne Robbins explains in the context of typography (one of the key elements of a presentation brand), design choices made by lawyers impact all three of the classical rhetorical appeals: pathos, logos, and ethos.⁹³ They impact pathos (emotion) because they set the “mood” and tenor of the document. They impact logos (logic) because they make sure the content is displayed so that the audience can understand and retain the information. And they demonstrate ethos (credibility) because they convey the expertise of the speaker.⁹⁴

This section will focus on four of the most important components of any presentation brand: (1) typography, (2) color, (3) transitions/animations, and (4) images. But before diving into an introduction to each, it is necessary to briefly discuss those tools that serve as default presentation brands: built-in software templates and firm- or organization-created templates. Many presentation design experts dismiss the use of these templates out of hand but there is certainly a place for them. After all, especially as these templates have become more professional and more modern, they allow non-designers to implement a cohesive

⁹² SCHWABISH, *supra* note 59, at 29.

⁹³ Robbins, *supra* note 9, at 110–11.

⁹⁴ *Id.*

presentation brand with the click of a button and zero effort or design knowledge.

But at the same time it is important to know which template to use for a given presentation and to be careful not to rely too much on these templates. Built-in templates from software packages tend to be overused as well as overly intricate or busy (and at times even unprofessional or juvenile).⁹⁵ Relatedly, firmwide templates tend to offer a one-size-fits-all marketing solution as opposed to a brand that fits the specific presentation purpose and audience. One simple example of this reality is that most organization-wide presentation templates include the name of the law firm or organization *on every slide*. Although this might be a useful design choice for a presentation pitching the firm to a new client, that brand does not align with the purpose of presenting to a jury where the firm name is not the focus of the lawyer’s presentation. Put another way, just as it would not make sense to put an appellate brief on firm stationery, the same is true for a digital presentation. Ultimately, a simple presentation brand that is created by a lawyer will often be a better choice than the busy, clip art filled designs popularized in presentation software. This is not to say that lawyers should never use them—but instead, if lawyers use them, they should use them intentionally and with care.

2.4.1. Typography

Legal presentations almost always include text and yet “[d]igital presentations are infamous for their terrible typography.”⁹⁶ As a result, one of the first and most important design choices that a legal presenter must make is what typography to use.⁹⁷ As trained lawyer and professional font designer Matthew Butterick explains, “Typography is the visual component of the written word.”⁹⁸ It “can help you engage readers, guide them, and ultimately persuade them. The more you appreciate what typography can do, the better a typographer you can become.”⁹⁹ Typography is particularly important in digital presentations for the simple reason that even “seemingly minor changes” in typography “can affect the reader’s perception of the document.”¹⁰⁰

⁹⁵ See SCHWABISH, *supra* note 59, at 42.

⁹⁶ Matthew Butterick, *Presentations*, TYPOGRAPHY FOR LAWYERS, <https://typographyforlawyers.com/presentations.html> (last visited Apr. 20, 2021).

⁹⁷ See SCHWABISH, *supra* note 59, at 51; Robbins, *supra* note 9, at 110 (“[E]ven with text alone, legal writers can create a picture using typography as paint on the canvas of the page.”).

⁹⁸ Matthew Butterick, *What is Typography*, TYPOGRAPHY FOR LAWYERS, <https://typographyforlawyers.com/what-is-typography.html> (last visited Apr. 1, 2021) (emphasis omitted).

⁹⁹ Matthew Butterick, *Why Typography Matters*, TYPOGRAPHY FOR LAWYERS, <https://typographyforlawyers.com/why-typography-matters.html> (last visited Apr. 1, 2021),

¹⁰⁰ Margolis, *supra* note 6, at 16.

But making strong typographic choices is not as easy as it might seem. “Good typography,” as designer Nate Kadlac puts it, is “a magic act. [Its] performance initially draws you in, but then quickly disappears into the background.”¹⁰¹ Performing this trick in legal presentations requires four effective choices: (1) quantity of typefaces, (2) choice of typefaces, (3) font size, and (4) emphasis.

Quantity of typefaces. As with so much of graphic design, when it comes to choosing the number of typefaces in a single presentation most experts agree fewer is better.¹⁰² The reason to use fewer typefaces (one or two at most) is to help reduce the audience’s need to decide why the typeface is changing. An audience will assume that a change in typeface is intentional—but it is very hard for the audience to visually see *what* that change means without further explanation. Just like a legal brief, memo, or book, it is better to use a single font or at most one font for headings and another for the primary text.

Typeface choice. There is never a single, perfect typeface choice.¹⁰³ But that does not mean that there are no bad choices. “Good typography,” as Matthew Butterick explains, “is measured by how well it reinforces the goals of the text, not by some abstract scale of merit,” and as a result “[y]our ability to produce good typography depends on how well you understand the goals of your text.”¹⁰⁴ Good typeface choice is not about being “pretty,” but about being effective given the purpose and audience of the presentation. The example that Butterick gives is highway signs.¹⁰⁵ The typeface used on most highway signs in the United States is not particularly pretty. But the purpose of that text is not to be seen as visually pleasing; it is “meant to be read quickly, from long distances, at odd angles, and under variable lighting and weather. It’s good typography because it supports the goals of the sign.”¹⁰⁶ By that metric the typeface choice is a resounding success.

Because legal presentations serve any number of goals, there is no one-size-fits-all approach to the most effective typeface choice. Nevertheless, there are some typefaces that simply have no place in legal

¹⁰¹ Nate Kadlac, *The Most Important Thing You Need to Know about Design*, KADLAC DESIGN, <https://www.kadlac.com/articles/the-most-important-thing-you-need-to-know-about-design> (last visited Mar. 21, 2021).

¹⁰² See, e.g., DUARTE, *supra* note 37, at 114 (“Select one typeface—two at most—for the entire slide deck.”); SCHWABISH, *supra* note 59, at 56 (“If you decide to use multiple font types, use them consistently and limit yourself to two or three—combining too many font types can be distracting and disorienting for your audience.”).

¹⁰³ Matthew Butterick, *What is Good Typography*, TYPOGRAPHY FOR LAWYERS, <https://typographyforlawyers.com/what-is-good-typography.html> (last visited Apr. 1, 2021).

¹⁰⁴ *Id.*

¹⁰⁵ *Id.*

¹⁰⁶ *Id.*

presentations. This includes typefaces that are “goofy.”¹⁰⁷ Again, to quote Butterick, “Distinctive is fine. Goofy is not. . . . Novelty fonts, script fonts, handwriting fonts, circus fonts . . . have no place in any document created by a lawyer. Save them for your next career as a designer of breakfast-cereal boxes.”¹⁰⁸ Some examples of corny or goofy typefaces that simply have no place in legal presentations include: *Noteworthy*, *Harrington*, and the typeface that everyone loves to hate: **Comic Sans**.

Beyond that, most typefaces are fair game depending on the purpose and audience for the presentation. At this point, the primary choice a presentation designer must make is whether to use a serif typeface or a sans-serif typeface. Serif typefaces are those that include an extra line or “wing” on the bottom of each letter.¹⁰⁹ Sans-serif typefaces, as their name suggests, do not. Although “the popular view among graphic design experts is to use serif [typefaces]”¹¹⁰ for “large blocks of texts,” the prevailing wisdom is that “sans serif [typefaces] are best for presentations.”¹¹¹ That is because “the letter forms [in sans-serif typefaces] are usually thicker than serif” and “serif [typefaces] can sometimes get lost in projectors with low resolution.”¹¹² Serif typefaces by contrast “read more easily in blocks of print text” because they “lead the eye from one letter to the next.”¹¹³

That said, there is no hard and fast rule that a lawyer may not use serif typefaces in a legal presentation. It really is a matter of personal preference, and in many situations a legal presenter might choose to use a serif typeface instead of a sans-serif one because sans-serif typefaces tend to look a bit more contemporary and bold (two words that rarely describe lawyers) whereas sans-serif typefaces can add a more professional feel. For some lawyers and some presentations, the desire for the latter will outweigh the former.

Some sans-serif typefaces that work particularly well in legal presentations include *Avenir*, *Century Gothic*, **Futura**, and **Franklin Gothic**. Some serif typefaces that work particularly well in legal presentations include *Century Schoolbook*, *Baskerville*, and *Didot*. But again, the key here is to be intentional about what the typeface conveys to the audience.

¹⁰⁷ Matthew Butterick, *Goofy Fonts*, *TYPOGRAPHY FOR LAWYERS*, <https://typographyforlawyers.com/goofy-fonts.html> (last visited Apr. 1, 2021).

¹⁰⁸ *Id.*

¹⁰⁹ Robbins, *supra* note 9, at 119.

¹¹⁰ *Id.*

¹¹¹ SCHWABISH, *supra* note 59, at 54.

¹¹² *Id.* at 56.

¹¹³ Robbins, *supra* note 9, at 120 (quoting LINDA L. LOHR, *CREATING GRAPHICS FOR LEARNING AND PERFORMANCE: LESSONS IN VISUAL LITERACY* 82 (2003)).

Text size. The third factor is far more important than the prior two. That is text size.¹¹⁴ If your audience cannot read the text of the slide they are *worse off* than if you excluded the text all together. Just because a presentation with small text *looks* like a more conventional legal document does not mean that the audience will be able to process small text in presentation form unless it is only being read in print or on a screen (and even then a bigger text size is often preferable for ease of reading). The prevailing wisdom among presentation-design experts is to make the font larger than one would in a traditional word-processed document no matter how a presentation is viewed by its audience.

How large should the text be? Guy Kawasaki recommends at least 30-point font.¹¹⁵ Jonathan Schwabish recommends at least 45-point.¹¹⁶ That said, given the range of presentations that lawyers are asked to create, the best advice is to make the font as big as possible given the circumstances. For perspective, the Slide 11 below shows the same typeface at different sizes.

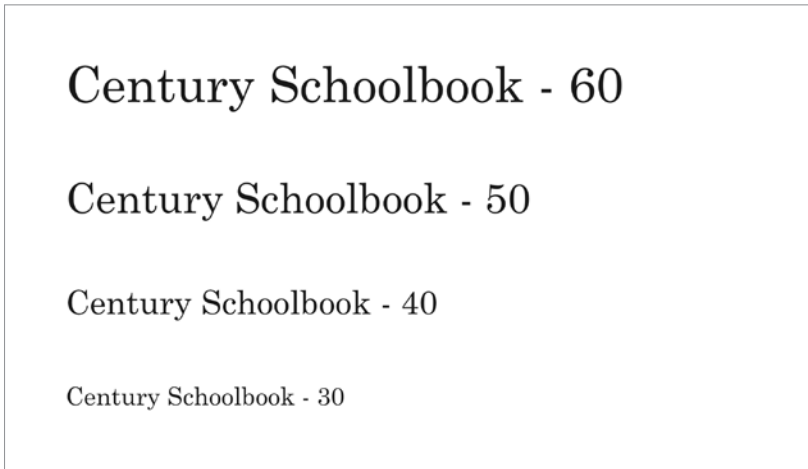
Slide 11¹¹⁷

The key rule here is that the presenter should “choose typography for [the] presentation based on the size and lighting conditions where it will be displayed” and not on conditions where the presentation is being created.¹¹⁸

¹¹⁴ See SCHWABISH, *supra* note 59, at 52–54.

¹¹⁵ Guy Kawasaki, *The 10/20/30 Rule of PowerPoint*, GUY KAWASAKI (Dec. 30, 2005), https://guykawasaki.com/the_102030_rule/.

¹¹⁶ SCHWABISH, *supra* note 59, at 52.

¹¹⁷ The idea for this slide is drawn from *id.* at 53.

¹¹⁸ Butterick, *supra* note 96.

Slide 12

Battery

Size 22 Font
133 Words

- The tort of battery requires the plaintiff to establish three elements by a preponderance of the evidence. First, the plaintiff must show that the defendant is the one who acted. Second, the plaintiff must show that the defendant's act intended to cause harm or offensive contact. And third, the plaintiff must show that the plaintiff was harmed by the contact.
- But what must the defendant actually intend? According to the Third Restatement of Torts, a person acts with intent if (a) the person acts with the purpose of producing that consequence; or (b) the person acts knowing that the consequence is substantially certain to result.
- But other cases disagree. Some courts have held that the defendant does not need to intend to cause the harm but instead must only intend the physical touching.

Slide 13

Battery

Size 36
60 Words

- The tort of battery requires the plaintiff to establish three elements by a preponderance of the evidence. First, the plaintiff must show that the defendant is the one who acted. Second, the plaintiff must show that the defendant's act intended to cause harm or offensive contact. And third, the plaintiff must show that the plaintiff was harmed by the contact.

Slide 14

Battery

Size 40
18 Words

- Defendant is the one who acted
- Defendant's act intended to cause harm or offensive contact.
- Plaintiff was harmed.

The other thing to remember about text size is the why. Legal presenters often use text that is too small not because they want to use small text intentionally but because smaller text allows for more text. This is not a good justification, and it is important for legal presenters to resist this temptation. Including less text per side not only allows the presenter to make that text bigger but that bigger text allows the audience to take it in more quickly and with less effort. For example, Slides 12, 13, and 14 each convey the elements of battery but with a different number of words and therefore are able to use different sized text.

Now, of course it is important not to take this recommendation to the extreme and simply display massive, one-word slides one after the other. But being intentional with text size can be the difference not only between a good presentation and great one—but it can also be the difference between a good presentation and a very bad one.

Emphasis. The final way to manipulate typography for the benefit of an audience is to emphasize or de-emphasize pieces of the text by making it look different from the rest of the text that surrounds it. Emphasis is a powerful tool because it allows the presentation designer to direct the audience's attention without losing the broader content or context of the slide. There are a number of different ways to emphasize or de-emphasize text, but some are more effective than others. The least effective tool for emphasis is ALL CAPS. ALL CAPS is an ineffective way to show emphasis (and candidly a poor typographic choice in any situation) because it slows down the audience's ability to read the text.¹¹⁹ A slightly better but still not ideal approach in digital presentations is italics and underlining. Although these techniques work well when used sparingly in blocks of text being read at close distance, they are often too subtle for digital presentations.

The two approaches that tend to work better in the text of digital presentations are making text bold or using contrasting colors for emphasis. The benefit of bold text is that it is different enough from the other text on the slide to allow the audience to quickly focus on what the presentation creator wants them to focus on. And text in a different (typically brighter) color is the easiest of all because it is easy for the audience to see a different meaning or purpose. Of course, if a presentation is printed (especially in black-and-white), bold text will serve the author's goals more effectively than text in a different color.

¹¹⁹ Robbins, *supra* note 9, at 115–16.

2.4.2. Color

Lawyers often make arguments about grey areas but they typically communicate those arguments in black text on white backgrounds.¹²⁰ Digital presentations are different—or at least they can be. Unlike traditional legal documents, digital presentations use color systematically and intentionally to convey meaning to the audience and “[c]olor used well can enhance and clarify a presentation. Color used poorly will obscure, muddle, and confuse.”¹²¹ When thinking about using color for the purpose of creating legal presentations it helps to think about 3Cs: consistency, contrast, and context.

Consistency. Like using consistent typeface choices, using a consistent color theme (or palette) helps convey information and depth to the audience. The challenge is that when the full spectrum of color is available it is difficult to know which colors to use and when. Some presentation experts recommend simplifying this by using just two: black and white. This simplicity has its benefits. It “is easy to implement (it’s the default), familiar to our eyes and brains (for example, most printed books), and has very high contrast (black text stands out clearly on a white page or slide).”¹²² If it is good enough for Apple, surely it is good enough for lawyers too, right? But there are issues with this black-and-white approach as well (at least when presentations are viewed on screen). Specifically, a black-and-white color scheme “do[es] not tap into the natural appeal of color and . . . [its] utility.”¹²³ As a result, using more than two colors is typically helpful in presentations, assuming that they will be viewed in color. Many novice presentation designers fall into one or the other extreme and use too many colors which can be more problematic than using too few. For example, some standard templates in presentation software include eight, ten, or even twelve colors. This is simply too much. The problem with using this many colors is that they start to lose any discernible meaning for the audience (if they had any intended meaning in the first place) and as a result they start harming the audience experience by requiring the audience to think about why a particular color is used as opposed to what the text says.

There is no magic number when using color in a legal presentation, but the approach I recommend is using five: (1) a dark main color, (2) a

¹²⁰ See Elizabeth G. Porter, *Imagining Law: Visual Thinking Across the Law School Curriculum*, 68 J. LEGAL EDUC. 8, 8 (2018) (referring to lawyers as having “a long tradition of black-and-white stodginess”).

¹²¹ Maureen Stone, *Choosing Colors for Data Visualization*, BUS. INTELLIGENCE NETWORK (Jan. 17, 2006), archived at https://www.perceptualedge.com/articles/b-eye/choosing_colors.pdf.

¹²² SCHWABISH, *supra* note 59, at 30.

¹²³ *Id.*

light main color, (3) an accent color, (4) a highlight color, and (5) a lowlight color. Used consistently, this “five-color theme” provides enough colors to convey information and layers while also allowing the audience to understand the meaning of each of these colors without a legend or oral explanation.

Contrast. The next decision is deciding what colors to use in your five-color theme. To help in that process the key tool in the presentation designer’s toolbox is contrast. Contrast is simply how one color stands out from other colors in the foreground, background, and nearby.¹²⁴ Contrast can be manipulated in three ways: hue, value, and saturation.¹²⁵ Hue is simply the “named description of color.”¹²⁶ For example, “blue” and “yellow” are hues. Value “is adjusted by adding black or white.”¹²⁷ As more black is added the color becomes darker and as more white is added it becomes lighter.¹²⁸ Saturation (also called chroma) is “the relative purity of the hue,” or how bright or dull a color is.¹²⁹

With presentation-design software you can manipulate any or all three of these components with exact precision. In choosing a color that provides a helpful contrast (as opposed to one that distracts or makes elements of the slides difficult to see), the keys are (1) to choose colors in the foreground and background with sufficiently different values (that is, colors that do not fade into the background color unless intentionally) and (2) choosing hues that work well together and are easy to understand for the audience.

Below are examples of the same three slides with different contrasts between foreground and background. Slide 15 uses a foreground color and a background color with the closest value. Slides 16 and 17 have progressively higher differences in value between foreground and background.

In terms of choosing specific hues, there are several different approaches that work. The first is to use a “monochromatic color scheme.”¹³⁰ A monochromatic scheme uses different shades of the same color (e.g., dark blue, blue, and light blue) along with white and/or black. This creates a unified and visually appealing color scheme, but it is less effective at drawing attention to key points.¹³¹ A complementary color

¹²⁴ See KOSSLYN, *supra* note 3, at 104; SCHWABISH, *supra* note 59, at 42.

¹²⁵ See SCHWABISH, *supra* note 59, at 35–38.

¹²⁶ *Id.* at 35.

¹²⁷ *Id.* at 36.

¹²⁸ *Id.*

¹²⁹ *Id.* at 38.

¹³⁰ *Id.* at 42.

¹³¹ See *id.*

Slide 15

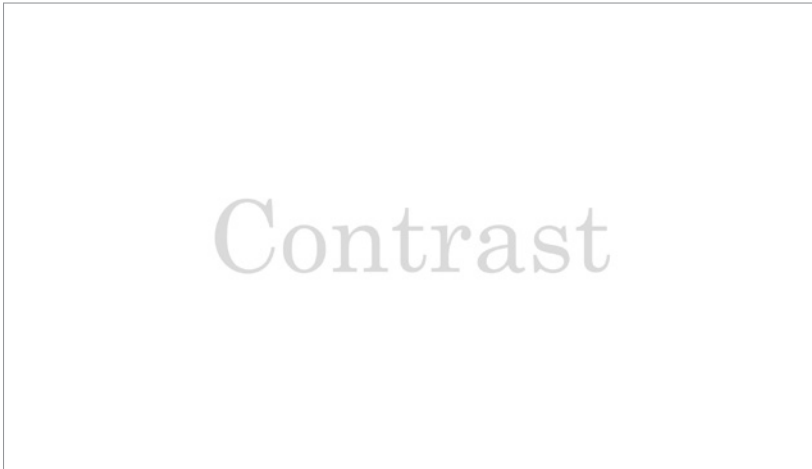

Slide 16



Slide 17



scheme that uses colors at opposite ends of the color wheel can also work.¹³² These colors are, by definition, contrasting. That said, using complementary colors can at times be too strong, and must be balanced by “adjusting the value or saturation of the colors.”¹³³ A third approach is to use “analogous colors” which “sit next to each other on the color wheel,” such as red, brown, and yellow.¹³⁴ These colors are naturally unified because they are close in hue.¹³⁵ The other option is to use a mix (for example, a monochromatic color scheme using an analogous color for highlighting key text). The one set of colors to avoid using together is red and green. This can cause serious accessibility issues for those with color-blindness who cannot recognize the difference.¹³⁶ The answer here again is just to be intentional in making color choices.

Context. The final decision that a digital presentation creator must make in terms of color is deciding on the appropriate color scheme for the context of the presentation. This is very important, but too often ignored. If a presentation is displayed on a projector in a dark room, most presentation experts recommend using a dark background with light text. These slides not only look more professional, but they also work particularly well because the text stands out and because the presenter can be the focal point as opposed to the bright backlit screen.¹³⁷ This is equally true in presentations that are displayed for a videoconference. Test this out the next time you are viewing a projected digital presentation. If the background is white (or light) see whether your eyes gravitate towards the screen or the speaker. Then do the same with a dark background, and the difference will quickly become apparent. The brightly lit background screams to the brain “look at me,” while the dark background basically gives the eye permission to focus on the speaker instead. That said, presentations that are printed work far better with dark text on a white background. Not only are they easier to print on white paper, but they also allow the audience to read in the way they are typically accustomed to. Presentations primarily viewed on a computer screen without the benefit of a presenter can really go either way.

¹³² *Id.* at 43.

¹³³ *Id.*

¹³⁴ *Id.* at 44.

¹³⁵ *Id.*

¹³⁶ See KOSSLYN, *supra* note 3, at 101; SCHWABISH, *supra* note 59, at 46.

¹³⁷ See David J.P. Phillips, *How to Avoid Death By PowerPoint*, TEDxSTOCKHOLM 2014 (Apr. 14, 2014), <https://www.youtube.com/watch?v=lwpi1Lm6dFo>; see also Butterick, *supra* note 96 (“When you’re designing for reading in the dark, your goal is to get the words on screen using the fewest photons.”).

But what about a presentation that has multiple audiences or modalities? For example, a presentation that is displayed on a screen during a client meeting and also printed out to share with the client for later review? In that circumstance the content of the presentation changes, but also the color scheme used should as well. The best practice in this situation is to actually prepare two versions of the presentation (one light text on dark background, one dark text on light background). If that is not possible given the circumstances, consider what the primary purpose of the presentation is and use that.

Finally, choosing colors that are appropriate to the context of the presentation is essential. This is not a pitch deck for a vacation to the Caribbean or a fifth-grade science experiment. This is a legal presentation. As a result, a professional (even if boring) color scheme typically works best for most legal presentations—unless the purpose of the presentation is to make it pop.

2.4.3. Animations and transitions

Digital presentations that are viewed on a screen (either a projector or individual computer monitor) often include animations and transitions. Animations (sometimes referred to as “builds”) are the way that different elements on a single slide appear sequentially. Transitions are what the audience sees between two slides. For example, if a slide contains four bullets but they are revealed one at a time, that is an animation. If one slide swipes from left to right to the next slide, that is a transition.

Animations and transitions are easy to apply to legal presentations but they should only be used carefully and intentionally, if at all. As Chris Anderson argues, “Many presenters sink in the dreaded quicksand of excessive transitions. Rule of thumb: Avoid nearly all of them.”¹³⁸ And as Nancy Duarte puts it, “It’s tempting to include every feature and flashy effect that’s available—but that would be like adding rhinestones to every outfit in your closet. You’d be blinded by all the bling when you opened the door, and you wouldn’t know what to pick.”¹³⁹

That is not to say that animations and transitions are useless to legal-presentation designers. At their core, animations and transitions are just ways to control the audience’s attention when moving from point to point or slide to slide. But if there is no specific reason to direct the audience’s attention to this transition then it is just a distraction. This is why transitions are rarely useful for lawyers. After all, what does the audience learn when one slide spins into another as opposed to merely just advancing naturally?

138 ANDERSON, *supra* note 56, at 124.

139 DUARTE, *supra* note 37, at 151.

Animations, by contrast, can work particularly well when presenting or viewing on a screen. Animations allow the presenter to control the audience's focus *on a single slide* and slowly reveal different components of a slide without losing the slide's larger context. The key to using animations effectively is (1) only using them when a slide should be viewed in pieces and (2) using specific animation types that call attention to the text and the connection to prior text, not to the animation itself. To accomplish this, the best animation is almost always labeled "appear." The "appear" animation is exactly how it sounds. The element appears on screen without any other flourish such as spinning, flying, or dancing. Again, the rule of thumb is, do not grab the audience's attention unless it specifically helps the audience.

Animations can be created automatically in most digital-presentation software tools. That said, a better approach is often a manual animation or what Jonathan Schwabish calls "layering."¹⁴⁰ This is where several individual slides are created which reveal one additional component (text, image, etc.) at a time, as opposed to a true animation which uses a single slide that just reveals one element at time. The benefit of layering is that the presentation creator can both emphasize what is being added but also de-emphasize what is no longer the focus. For example, the first set of slides below (Slide 18) presents three bullet points using an automatic animation (*see next page*). The second set of slides (Slide 19) presents the same three bullet points using manual layering. The second set more clearly directs the audience's focus by using layering across multiple slides.

Ultimately, the key for any animations (automatic or manual) is that the audience should understand their purpose without distraction. "Just like actors on a stage, elements can enter your slide, interact, and then leave the scene. But the movement should seem natural and controlled, not busy and frenetic."¹⁴¹ And just like it would be both surprising and visually jarring to have an actor jump up and down in the corner, there is no reason to do that in a legal presentation.

2.4.4. Images

The final component of a presentation brand is the use of images. "Images," as Richard Sherwin notes, "do not merely add to words. They are transformative, both qualitatively and quantitatively, which is to say, both in terms of the content that they display and the efficacy of emotion and belief that they evoke."¹⁴² Images are one of the reasons why digital presentations can be so much richer than more traditional legal documents.

¹⁴⁰ See SCHWABISH, *supra* note 59, at 73–78.

¹⁴¹ DUARTE, *supra* note 37, at 152.

¹⁴² Richard K. Sherwin, *Visual Jurisprudence: Visualizing Law in the Digital Age*, 57 N.Y. L. SCH. L. REV. 11, 15 (2012–2013).

Slide 18

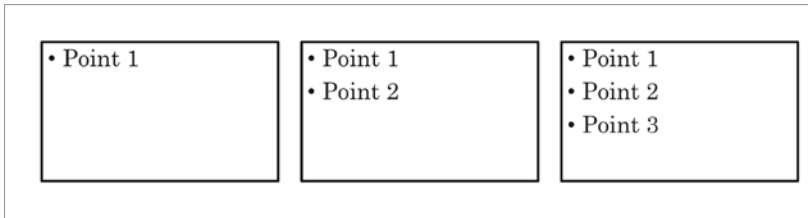

Slide 19

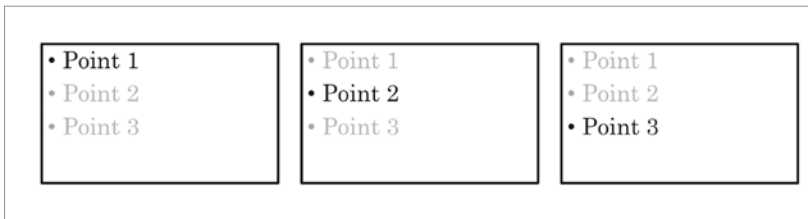

But as Steve Johansen and Ruth Anne Robbins explain, there are different kinds of images in legal documents.¹⁴³ Some images are documentary—that is, they show something that exists extrinsically in the world.¹⁴⁴ Others are analytical—that is, they help explain the analysis.¹⁴⁵ And among analytical images, there are many different purposes that range from the decorative (visually interesting but with limited direct connection to the analysis) to the transformative (help change the way the audience “perceives an issue”).¹⁴⁶ Presentations can use all of these image types effectively and in a number of different ways. The key point for purposes of the presentation brand, however, is *how* they are displayed. For that, the keys are to use (1) high-quality images, (2) laid out in a visually helpful way, and (3) that are properly licensed.

First, the importance of using “high-quality” images is both a matter of pathos (emotion) and logos (logic). A grainy or pixelated image or an image that includes details that are too small can have the same effect that sloppy citations can have for other types of legal documents. It indicates a lack of professionalism on the part of the presenter. More than that, if the audience cannot quickly and clearly see the image, the image is distracting from the content as opposed to supporting it.

Second, although there are many ways to lay out images in digital presentations, the size and placement of these images is critical to ensure

¹⁴³ Johansen & Robbins, *supra* note 6, at 63.

¹⁴⁴ *Id.*

¹⁴⁵ *Id.* at 64.

¹⁴⁶ *Id.* at 69.

the images enhance the audience's understanding, rather than detract from it. When deciding how large an image should be and how to crop the image, it is a good practice to think in terms of the rule of thirds.¹⁴⁷ The rule of thirds says that in designing any image (or here slide) you should mentally divide it into nine equal boxes by dividing it horizontally and vertically in three and then placing key focus points at the intersections of these lines. The underlying rationale in this practice is to align a slide's text with its images in a way that intuitively makes sense to the viewer.¹⁴⁸ Although image size will likely depend upon the type of slide being created, there are three major compositions that arise from following the rule of thirds: a full screen image, an almost-full screen image plus a caption, and a one-third-screen image (on the right, left, bottom, or top) with the rest of the slide dedicated to text and/or empty space.¹⁴⁹

Third, it is important to use properly licensed images—after all, these are *legal* presentations. Thankfully there are a number of places on the Internet that allow presenters to find royalty-free images for use in any presentation (e.g., <http://www.unsplash.com>). It is also possible to find royalty-free images using an image search engine and limiting the search based on the appropriate license.

2.5. Step five: Slide design

At Step Five it is finally time to create individual slides using design software. For many lawyers this is the most intimidating step given that they did not become professional graphic designers (and usually for good reason). But remember at this point in the process the slide is already 80% complete: the presentation creator knows the purpose and audience for the slide, the content and goals for the slide as well as how it fits into the logical flow of the larger presentation, and the basic design elements to use by virtue of having a presentation brand.

The only task at this point is to “think visually”¹⁵⁰ and convey that content to the audience in a meaningful and visually accessible way using a series of digital objects: text, shapes, images, and other media. But that of course is like saying that the “only” task for a painter after generating an idea and compiling supplies is to make some brush strokes. Given that “[l]egal analysis can be conceptualized visually in any number of ways,”¹⁵¹ this is still a challenge.

¹⁴⁷ See SCHWABISH, *supra* note 59, at 124–25.

¹⁴⁸ See *id.* at 123–24.

¹⁴⁹ See *id.* at 118.

¹⁵⁰ RITTER, *supra* note 5, at 145.

¹⁵¹ Johansen & Robbins, *supra* note 6, at 73.

But do not despair. For some slides, the process is straightforward. Documentary slides, for example, that simply display a map of a key location in a case, a quote from a key filing, or an eyewitness video of an alleged crime can be created in seconds. And for other slides, like guide slides and content slides, that do require more creativity, there are several tools and techniques that help the presentation creator transform an idea expressed in words into a slide that the audience is able to effectively consume. The three techniques this section will highlight are (1) including less on each slide, (2) using preattentive attributes, and (3) turning words into diagrams.

Less is more. The digital-presentation creator's most important asset is the audience's focus, and the easiest way to control or direct that focus is by including less on each slide. This technique is recommended universally by presentation design experts. Jonathan Schwabish talks about "the principle of focus," and says that by "put[ting] *less* on [their] slides—less text, less clutter—all with the goal of helping . . . [the presenter can guide the] audience's attention to what is actually important."¹⁵² Steven Kosslyn refers to the same idea as the "principle of capacity limitations," reminding presenters that "[p]eople have a limited capacity to retain and to process information, and so will not understand a message if too much information must be retained or processed."¹⁵³ Garr Reynolds agrees that "most people have not been exposed to the idea of making a visual stronger by stripping it down to its essence."¹⁵⁴ And Nancy Duarte reaches the same conclusion, explaining that "[r]esearch shows that people learn more effectively from multimedia messages when they're stripped of extraneous words, graphics, animation, and sounds."¹⁵⁵ These "extras," she writes, "overtax the audience's cognitive resources."¹⁵⁶

Of course, actually including less on each slide is easier said than done. One helpful technique for operationalizing this advice is to include no more than six objects—headers, bullet points, images, footers, etc.—per slide. The reason, as David J.P. Phillips, explains in his TEDx Talk "How to avoid death by PowerPoint" which has been viewed over 3 million times, is that a slide that contains any more than six images requires the audience to "count" those objects and review each one at a time whereas the typical audience member can "see" six objects of an image all at the same time without thinking about each one individually.¹⁵⁷ He reaches this

152 SCHWABISH, *supra* note 59, at 51.

153 KOSSLYN, *supra* note 3, at 11.

154 REYNOLDS, *supra* note 60, at 125.

155 DUARTE, *supra* note 37, at 113–14.

156 *Id.* at 114.

conclusion based on research that shows it takes the average person *500% less time* to count to six objects than it does to count to seven.¹⁵⁸ Of course, this does not mean that *every* slide must be fewer than seven objects (or that some slides with more than seven objects will still take the audience time to understand), but it is a helpful guide in exercising restraint.

But what if there is simply more that *needs* to go on a slide? Then a presenter has two options: (1) edit down or (2) spread across multiple slides. For some slides the first option is the best way to accomplish the goal. For example, assume that a title slide includes eight objects: the title of the presentation, an image, the presenter’s name, their office phone number, their address, their fax number, their mailing address, and the presentation date. This slide can easily be edited down so that the audience can spend less time reading and more time listening (after all, what are the chances that the audience is going to write down the fax number and send a fax—and if they needed to what are the chances they could not find that information using a simple Google search). In other circumstances, the second option of spreading information across multiple slides is better. For example, if a lawyer needed to display an organizational chart with more than six individuals, it might be better to break that chart into pieces and cover one line of reports at a time to allow for fewer (and easier to see) names and images per slide. To quote Phillips, “[T]he amount of slides in your [presentation] has never been the problem. It is the amount of objects per slide which have been the problem.”¹⁵⁹

Preattentive attributes. Preattentive attributes are “visual properties that we notice without using conscious effort to do so.”¹⁶⁰ In these visual properties we can see and find meaning without actively thinking. As a result, the use of preattentive attributes allow an image to be understood more quickly as a whole as opposed to merely representing the sum of its parts. For example, an effective presentation designer might use any number of the following to help convey information to the reader without requiring active thinking: contrast, position (showing hierarchy up to down and left to right), scale (bigger is more important), hierarchy (indentation demonstrates a sub-part to main heading), emphasis (an arrow or box means more important), and the use of negative space (less densely displayed information is more important).¹⁶¹ In each case, these preat-

157 Phillips, *supra* note 137.

158 *Id.*

159 *Id.*

160 Meagan Longoria, *Design Concepts for Better Power BI Reports—Part 2: Preattentive Attributes*, DATA SAVVY (Nov. 30, 2017), <https://datasavvy.me/2017/11/30/design-concepts-for-better-power-bi-reports-part-2-preattentive-attributes/>; see also SCHWABISH, *supra* note 59, at 84–85.

161 See SCHWABISH, *supra* note 59, at 84–85.

tentive attributes allow the presentation creator to control the audience’s attention by explicitly placing objects in an order that allows the audience to understand them implicitly. Using these attributes does not require a degree in graphic design. Instead, they just require the lawyer creating the slides to be intentional, not just about what they display but how they display it.

Turn words into diagrams. One of the best parts about presenting legal analysis in digital presentations is the ability to use diagrams instead of prose.¹⁶² This is especially true when lawyers can use diagrams with which their audience is already familiar. These familiar diagrams create what Nancy Duarte calls a “visual taxonomy” or recognizable format that allows the audience to immediately understand subconsciously *how* information fits together.¹⁶³ Below are a number of examples of common slide types and familiar diagrams that a lawyer can use to share this information in a format that is easier to consume than bullet points.

Order of Events	Timeline
Steps or Process	Flowchart
Relative Percentages	Pie Chart
Changing Values over Time	Line Graph
Hierarchies of People	Organizational Chart
Hierarchies of Information	Pyramid
Comparison of Two Sets of Information	T Chart
Information that Shares Some But Not All Characteristics	Venn Diagram

Of course, this is not to imply that legal presentations should never use bullet points (they often should!) nor is it to argue that every time a lawyer conveys a particular type of information it must be conveyed using the associated visual diagram. But it is instead a reminder that lawyers *already know* how to display information and text visually. It is a matter of consciously and intentionally becoming a producer of information that taps into the visual heuristics rather than a mere consumer of those visual heuristics.

162 Rosman, *supra* note 5, at 71 (“Advances in computers make it relatively easy to integrate images with text, and there’s every reason to think that courts (and other consumers of legal work) would welcome innovative displays of information.”).

163 DUARTE, *supra* note 37, at 143.

2.6. Step six: Purpose and audience audit (slide editing)

It is surprising that lawyers feel it is important to edit and rewrite briefs, memos, and even emails but too often do not give the same attention to editing digital presentations. This is a critical mistake. No deliverable is “file ready” after the first draft and every first draft can be strengthened by edits for content, organization, and substance. The same is true for digital presentations. In fact, it is probably even more true given the added complexity of editing both the presentation and the deliverable it accompanies.

The key takeaway here is that digital presentations require the same level of rewriting, editing, and polishing as any other legal document. And, in order to do so, it is helpful to conduct an “audience audit.” An audience audit is a simple but structured process of review that reviews both individual slides and the presentation as a whole from the perspective of the audience for the presentation.

This audience audit proceeds in three steps. First, it starts with analyzing the content and conclusions of the digital presentations—the actual legal analysis. Is the analysis grounded in the correct law? Are the legally significant facts sufficiently accounted for? Second, the audit moves to a review of the design and organization. Do the slides display the content in an easy-to-digest visual format? Do they supplement as opposed to distract from the deliverable that accompanies the presentation, such as the oral presentation? Is the audience able to follow the organizational structure of the presentation? Do any slides need to be reorganized? Are any slides going to distract the audience from the presentation’s focus? Third and finally, the audience audit requires a technical and technological edit. At this stage it is not only important to fix any technical errors (typos, imprecise phrases) but also images, transitions, animations, and failures to adhere to the presentation brand. If the presentation is delivered orally, it is extremely helpful to at least practice (if not script) the oral presentation and placement of slides in the presentation. If the presentation will only be shared visually, it is worth reading one last time out loud or in the format that it will be reviewed (on a screen or in print). By reviewing the presentation in this way, the presenter knows they are not losing an opportunity to convey ethos (authority) and, even more importantly, can be confident that the digital presentation is ready to accomplish its intended purpose for its intended audience.

3. What's next

This article seeks to jump-start a more robust conversation about legal presentations in the academy. It is part proof-of-concept that lawyers are increasingly asked to convey information using digital presentations and part instruction manual for lawyers (and future lawyers) to create better presentations in a more systematic and intentional way no matter the practice area or context. But this is just the beginning of that conversation. Future questions to ask about legal presentations are both qualitative and quantitative. For example, the legal community would benefit from a robust survey of the exact extent to which digital presentations are used by practicing lawyers, a more detailed discussion of what clients and particular industries have come to expect when it comes to digital presentations, and updated explorations of how adjudicators feel about the use of digital presentations that accompany oral advocacy.

Another important step in this conversation is to find ways to introduce the teaching of digital presentations more robustly into the law school curriculum.¹⁶⁴ To use Elizabeth Porter's words, the goal should be to "change through evolution, not revolution. . . . [I]t is possible—and worthwhile—to integrate visual learning and visual analysis into doctrinal, clinical, and writing courses without tossing your textbooks or reconceptualizing your pedagogical methods."¹⁶⁵

In my own first-year legal writing course, I teach my students how to create digital presentations as part of a mock supervisor presentation after they draft their first predictive memo. Other legal practice/legal writing professors may already be including these skills in this or other ways. The benefits of integrating these exercises into the first-year curriculum are three-fold. First, they prepare law students for the tasks they are likely to encounter in their first internships and legal jobs. Second, they fit naturally into the typical legal writing curriculum and can add value without adding significant class time. And third, integrating presentations into classwork helps students refine their writing and research (and identify the holes in that writing and research) by being forced to present the same concepts in a different genre of communication. Legal presentations can also be easily introduced as part of clinical education (to the extent that they are not already introduced).

The final step is finding ways to better integrate presentation design into the toolbox of practicing lawyers. Despite the fact that presentation-

¹⁶⁴ See Porter, *supra* note 120, at 9 ("[I]t's time, thoughtfully, to integrate visual literacy and visual advocacy throughout the law school curriculum.").

¹⁶⁵ *Id.* at 10.

design software has been around for more than twenty-five years, many attorneys simply see presentation design as something that they are not prepared to do, not skilled enough to do, and not required to learn. A random smattering of one-time CLEs is not enough to solve this problem. It is important therefore that the profession continue to find and build concrete opportunities and tools to teach presentation design in more systematic ways to experienced attorneys and new attorneys alike. This article hopefully provides a start to that conversation.